



XLF224-512-FB374 Datasheet



2020/10/05

Document Number: X009389

Table of Contents

1	xCORE Multicore Microcontrollers	2
2	XLF224-512-FB374 Features	4
3	Pin Configuration	5
4	Signal Description	6
5	Example Application Diagram	12
6	Product Overview	13
7	PLL	16
8	Boot Procedure	17
9	Memory	18
10	JTAG	19
11	Board Integration	20
12	Electrical Characteristics	23
13	Package Information	27
14	Ordering Information	28
	Appendices	29
A	Configuration of the XLF224-512-FB374	29
B	Processor Status Configuration	31
C	Tile Configuration	41
D	Node Configuration	48
E	JTAG, xSCOPE and Debugging	56
F	Schematics Design Check List	58
G	PCB Layout Design Check List	60
H	Associated Design Documentation	61
I	Related Documentation	61
J	Revision History	62

TO OUR VALUED CUSTOMERS

It is our intention to provide you with accurate and comprehensive documentation for the hardware and software components used in this product. To subscribe to receive updates, visit <http://www.xmos.com/>.

XMOS Ltd. is the owner or licensee of the information in this document and is providing it to you "AS IS" with no warranty of any kind, express or implied and shall have no liability in relation to its use. XMOS Ltd. makes no representation that the information, or any particular implementation thereof, is or will be free from any claims of infringement and again, shall have no liability in relation to any such claims.

XMOS and the XMOS logo are registered trademarks of XMOS Ltd in the United Kingdom and other countries, and may not be used without written permission. Company and product names mentioned in this document are the trademarks or registered trademarks of their respective owners.



1 xCORE Multicore Microcontrollers

The xCORE200 Series is a comprehensive range of 32-bit multicore microcontrollers that brings the low latency and timing determinism of the xCORE architecture to mainstream embedded applications. Unlike conventional microcontrollers, xCORE multicore microcontrollers execute multiple real-time tasks simultaneously and communicate between tasks using a high speed network. Because xCORE multicore microcontrollers are completely deterministic, you can write software to implement functions that traditionally require dedicated hardware.

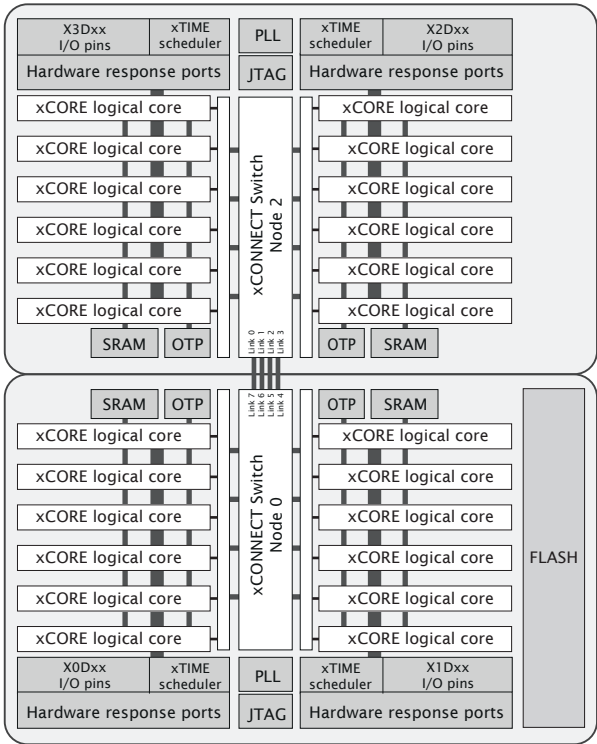

Figure 1:
XLF224-512-FB374 block diagram

Key features of the XLF224-512-FB374 include:

- ▶ **Tiles:** Devices consist of one or more xCORE tiles. Each tile contains between five and eight 32-bit xCOREs with highly integrated I/O and on-chip memory.
- ▶ **Logical cores** Each logical core can execute tasks such as computational code, DSP code, control software (including logic decisions and executing a state machine) or software that handles I/O. Section 6.1
- ▶ **xTIME scheduler** The xTIME scheduler performs functions similar to an RTOS, in hardware. It services and synchronizes events in a core, so there is no requirement for interrupt handler routines. The xTIME scheduler triggers cores on events generated by hardware resources such as the I/O pins, communication channels and timers. Once



triggered, a core runs independently and concurrently to other cores, until it pauses to wait for more events. Section 6.2

- ▶ **Channels and channel ends** Tasks running on logical cores communicate using channels formed between two channel ends. Data can be passed synchronously or asynchronously between the channel ends assigned to the communicating tasks. Section 6.5
- ▶ **xCONNECT Switch and Links** Between tiles, channel communications are implemented over a high performance network of xCONNECT Links and routed through a hardware xCONNECT Switch. Section 6.6
- ▶ **Ports** The I/O pins are connected to the processing cores by Hardware Response ports. The port logic can drive its pins high and low, or it can sample the value on its pins optionally waiting for a particular condition. Section 6.3
- ▶ **Clock blocks** xCORE devices include a set of programmable clock blocks that can be used to govern the rate at which ports execute. Section 6.4
- ▶ **Memory** Each xCORE Tile integrates a bank of SRAM for instructions and data, and a block of one-time programmable (OTP) memory that can be configured for system wide security features. Section 9
- ▶ **PLL** The PLL is used to create a high-speed processor clock given a low speed external oscillator. Section 7
- ▶ **Flash** The device has a built-in 2MBflash. Section 8
- ▶ **JTAG** The JTAG module can be used for loading programs, boundary scan testing, in-circuit source-level debugging and programming the OTP memory. Section 10

1.1 Software

Devices are programmed using C, C++ or xC (C with multicore extensions). XMOS provides tested and proven software libraries, which allow you to quickly add interface and processor functionality such as USB, Ethernet, PWM, graphics driver, and audio EQ to your applications.

1.2 xTIMEcomposer Studio

The xTIMEcomposer Studio development environment provides all the tools you need to write and debug your programs, profile your application, and write images into flash memory or OTP memory on the device. Because xCORE devices operate deterministically, they can be simulated like hardware within xTIMEcomposer: uniquely in the embedded world, xTIMEcomposer Studio therefore includes a static timing analyzer, cycle-accurate simulator, and high-speed in-circuit instrumentation.

xTIMEcomposer can be driven from either a graphical development environment, or the command line. The tools are supported on Windows, Linux and MacOS X and available at no cost from [xmos.ai/software-tools](https://www.xmos.ai/software-tools).

2 XLF224-512-FB374 Features

▶ **Multicore Microcontroller with Advanced Multi-Core RISC Architecture**

- 24 real-time logical cores on 4 xCORE tiles
- Cores share up to 2000 MIPS
 - Up to 4000 MIPS in dual issue mode
- Each logical core has:
 - Guaranteed throughput of between $\frac{1}{5}$ and $\frac{1}{6}$ of tile MIPS
 - 16x32bit dedicated registers
- 167 high-density 16/32-bit instructions
 - All have single clock-cycle execution (except for divide)
 - 32x32→64-bit MAC instructions for DSP, arithmetic and user-definable cryptographic functions

▶ **Programmable I/O**

- 256 general-purpose I/O pins, configurable as input or output
 - Up to 56 x 1bit port, 22 x 4bit port, 13 x 8bit port, 6 x 16bit port, 4 x 32bit port
 - 8 xCONNECT links
- Port sampling rates of up to 60 MHz with respect to an external clock
- 128 channel ends (32 per tile) for communication with other cores, on or off-chip

▶ **Memory**

- 512KB internal single-cycle SRAM (max 128KB per tile) for code and data storage
- 32KB internal OTP (max 8KB per tile) for application boot code
- 2MB internal flash for application code and overlays

▶ **Hardware resources**

- 24 clock blocks (6 per tile)
- 40 timers (10 per tile)
- 16 locks (4 per tile)

▶ **JTAG Module for On-Chip Debug**

▶ **Security Features**

- Programming lock disables debug and prevents read-back of memory contents
- AES bootloader ensures secrecy of IP held on external flash memory

▶ **Ambient Temperature Range**

- -40 °C to 85 °C

▶ **Speed Grade**

- 40: 2000 MIPS

▶ **Power Consumption**

- 1140 mA (typical)

▶ **374-pin FBGA package 0.8 mm pitch**

3 Pin Configuration

	1	2	3	4	5	6	7	8	9	10	11	12	13	14	15	16	17	18	19	20	21	
A	GND	VDDIO	X1D11	X1D32	X1D26	VDDIOT	X1D41	X2D31	X2D29	TDI	VDDIO	CLK	TDO	X3D32	X3D30	VDDIOT ₂	X2D31	X2D29	X2D32	VDDIO	GND	
B	X2D37	X2D36	X1D10	X1D33	X1D27	X1D42	X1D40	X2D30	X2D28	X2D36	GND	RST_N	TCK	X3D33	X3D31	X3D27	X2D30	X2D28	X2D27	X2D26	X2D35	
C	X2D39	X2D38	VDD	X1D30	X1D28	X1D43	GND	X2D33	X2D32	MODE1	OTP_VCC	TRST_N	X3D10	X3D29	GND	X3D43	X3D41	X2D33	VDD	X2D25	X2D34	
D	X2D41	X2D40	X1D34	X1D31	X1D29	GND	VDDIO	NC	DEBUG_N	MODE0		TMS	X3D11	X3D28	X3D26	X3D42	X3D40	X2D70	X3D00	X3D01	X2D24	
E	X2D43	X2D42	X1D35	VDD	VDD	GND	VDDIO	VDD	VDD				VDD	VDD	VDDIO	GND	VDD	VDD	VDD	X2D69	X3D08	X3D09
F	X1D36	VDDIO	GND	VDD	VDD	VDD	VDD	VDD	VDD	PLL_ASDIO	PLL_AVDIO	VDD	VDD	VDD	VDD	VDD	VDD	VDD	VDD	GND	VDDIO	X2D68
G	X1D49	X1D50	X1D51	NC	NC	NC	NC	NC	NC				NC	NC	NC	NC	NC	NC	NC	X2D67	X2D66	X2D65
H	X1D53	X1D52	VDD																	VDD	X2D63	X2D64
J	X1D54	X1D55	VDD		GND	GND	GND	GND	GND				GND	GND	GND	GND	GND	GND		VDD	X2D62	X2D61
K	X1D58	X1D57	X1D56		GND	GND	GND	GND	GND				GND	GND	GND	GND	GND			X2D56	X2D57	X2D58
L	VDDIO	GND	X1D61		GND	GND	GND	GND	GND				GND	GND	GND	GND	GND			X2D55	GND	VDDIO
M	X1D64	X1D63	X1D62		GND	GND	GND	GND	GND				GND	GND	GND	GND	GND			X2D54	X2D53	X2D52
N	X1D65	X1D66	VDD		GND	GND	GND	GND	GND				GND	GND	GND	GND	GND			VDD	X2D50	X2D51
P	X1D68	X1D67	VDD																	VDD	X3D06	X3D07
R	X1D69	X1D70	X1D67	NC	NC	NC	NC	NC	NC				NC	NC	NC	NC	NC	NC	NC	X2D49	X3D04	X3D05
T	X1D38	VDDIO	GND	VDD	VDD	VDD	VDD	VDD	VDD	VDD	GND	VDD	VDD	VDD	VDD	VDD	VDD	VDD	VDD	GND	VDDIO	X3D03
U	X1D17	X1D16	X1D39	VDD	VDD	GND	VDDIO	NC	VDD			VDDIO		VDD	VDD	VDDIO	GND	VDD	VDD	NC	X2D19	X2D22
V	X1D19	X1D18	X2D01	X2D02	X2D08	X2D11	NC	X1D14	X1D25	X2D21	NC	X3D23	X2D06	X2D07	NC	NC	X3D15	X3D21	X2D12	X2D17	X2D18	
W	X2D10	X1D22	VDDIO	X2D03	X2D09	NC	GND	X1D15	X2D14	X2D12	X2D23	X2D00	X2D04	X2D06	GND	NC	X3D14	X3D20	VDDIO	X2D23	X2D16	
Y	X1D23	X2D00	X2D04	X2D06	X1D12	NC	X1D24	X1D20	X2D15	X2D13	GND	X2D11	X2D02	X2D08	X3D13	NC	X2D14	X2D20	X3D24	X2D13	X2D22	
AA	GND	VDDIO	X2D05	X2D07	X1D13	NC	NC	X1D21	X2D20	X2D22	VDDIO	X3D12	X2D03	X2D09	NC	NC	X2D15	X2D21	X3D25	VDDIO	GND	



4 Signal Description

This section lists the signals and I/O pins available on the XLF224-512-FB374. The device provides a combination of 1bit, 4bit, 8bit and 16bit ports, as well as wider ports that are fully or partially (gray) bonded out. All pins of a port provide either output or input, but signals in different directions cannot be mapped onto the same port.

Pins may have one or more of the following properties:

- ▶ PD/PU: The IO pin has a weak pull-down or pull-up resistor. The resistor is enabled during and after reset. Enabling a link or port that uses the pin disables the resistor. Thereafter, the resistor can be enabled or disabled under software control. The resistor is designed to ensure defined logic input state for unconnected pins. It should not be used to pull external circuitry. Note that the resistors are highly non-linear and only a maximum pull current is specified in Section 12.3.
- ▶ ST: The IO pin has a Schmitt Trigger on its input.
- ▶ IOT: The IO pin is powered from VDDIOT (X1) or VDDIOT_2 (X3), not VDDIO
- ▶ IO: the pin is powered from VDDIO

Power pins (9)			
Signal	Function	Type	Properties
GND	Digital ground	GND	
OTP_VCC	OTP power supply	PWR	
PLL_AGND	Analog ground for PLL	PWR	
PLL_AVDD	Analog power for PLL	PWR	
VDD	Digital tile power	PWR	
VDD33	Peripheral power	PWR	
VDDIO	Digital I/O power	PWR	
VDDIOT	Digital I/O power (top)	PWR	
VDDIOT_2	Digital I/O power (top, X3)	PWR	

JTAG pins (6)			
Signal	Function	Type	Properties
RST_N	Global reset input, active low	Input	IO, PU, ST
TCK	Test clock	Input	IO, PD, ST
TDI	Test data input	Input	IO, PU
TDO	Test data output	Output	IO, PD
TMS	Test mode select	Input	IO, PU
TRST_N	Test reset input, active low	Input	IO, PU, ST

I/O pins (176)				
Signal	Function		Type	Properties
X0D00		1A ⁰	I/O	IO, PD
X0D01	X ₀ L3 _{out} ²	1B ⁰	I/O—	IO, PD
X0D02		4A ⁰ 8A ⁰ 16A ⁰ 32A ²⁰	I/O	IO, PD
X0D03		4A ¹ 8A ¹ 16A ¹ 32A ²¹	I/O	IO, PD
X0D04		4B ⁰ 8A ² 16A ² 32A ²²	I/O—	IO, PD
X0D05		4B ¹ 8A ³ 16A ³ 32A ²³	I/O—	IO, PD
X0D06		4B ² 8A ⁴ 16A ⁴ 32A ²⁴	I/O—	IO, PD
X0D07		4B ³ 8A ⁵ 16A ⁵ 32A ²⁵	I/O—	IO, PD
X0D08		4A ² 8A ⁶ 16A ⁶ 32A ²⁶	I/O	IO, PD
X0D09		4A ³ 8A ⁷ 16A ⁷ 32A ²⁷	I/O	IO, PD
X0D10	X ₀ L3 _{out} ³	1C ⁰	I/O—	IO, PD
X0D11		1D ⁰	I/O	IO, PD
X0D12		1E ⁰	I/O	IO, PD
X0D13		1F ⁰	I/O	IO, PD
X0D14		4C ⁰ 8B ⁰ 16A ⁸ 32A ²⁸	I/O	IO, PD
X0D15		4C ¹ 8B ¹ 16A ⁹ 32A ²⁹	I/O	IO, PD
X0D20		4C ² 8B ⁶ 16A ¹⁴ 32A ³⁰	I/O	IO, PD
X0D21		4C ³ 8B ⁷ 16A ¹⁵ 32A ³¹	I/O	IO, PD
X0D22		1G ⁰	I/O	IO, PD
X0D23		1H ⁰	I/O	IO, PD
X0D28		4F ⁰ 8C ² 16B ²	I/O	IO, PD
X0D29		4F ¹ 8C ³ 16B ³	I/O	IO, PD
X0D30		4F ² 8C ⁴ 16B ⁴	I/O	IO, PD
X0D31		4F ³ 8C ⁵ 16B ⁵	I/O	IO, PD
X0D32		4E ² 8C ⁶ 16B ⁶	I/O	IO, PD
X0D33		4E ³ 8C ⁷ 16B ⁷	I/O	IO, PD
X0D36		1M ⁰ 8D ⁰ 16B ⁸	I/O	IO, PD
X0D37	X ₀ L0 _{in} ⁴	1N ⁰ 8D ¹ 16B ⁹	I/O	IO, PD
X0D38	X ₀ L0 _{in} ³	1O ⁰ 8D ² 16B ¹⁰	I/O	IO, PD
X0D39	X ₀ L0 _{in} ²	1P ⁰ 8D ³ 16B ¹¹	I/O	IO, PD
X0D40	X ₀ L0 _{in} ¹	8D ⁴ 16B ¹²	I/O	IO, PD
X0D41	X ₀ L0 _{in} ⁰	8D ⁵ 16B ¹³	I/O	IO, PD
X0D42	X ₀ L0 _{out} ⁰	8D ⁶ 16B ¹⁴	I/O	IO, PD
X0D43	X ₀ L0 _{out} ¹	8D ⁷ 16B ¹⁵	I/O	IO, PD
X1D10		1C ⁰	I/O	IO, PD
X1D11		1D ⁰	I/O	IO, PD
X1D12		1E ⁰	I/O	IO, PD
X1D13		1F ⁰	I/O	IO, PD
X1D14		4C ⁰ 8B ⁰ 16A ⁸ 32A ²⁸	I/O	IO, PD
X1D15		4C ¹ 8B ¹ 16A ⁹ 32A ²⁹	I/O	IO, PD
X1D16	X ₀ L3 _{in} ¹	4D ⁰ 8B ² 16A ¹⁰	I/O	IO, PD

(continued)



Signal	Function	Type	Properties
X1D17	$X_0L3_{in}^0$ 4D ¹ 8B ³ 16A ¹¹	I/O	IO, PD
X1D18	$X_0L3_{out}^0$ 4D ² 8B ⁴ 16A ¹²	I/O	IO, PD
X1D19	$X_0L3_{out}^1$ 4D ³ 8B ⁵ 16A ¹³	I/O	IO, PD
X1D20	4C ² 8B ⁶ 16A ¹⁴ 32A ³⁰	I/O	IO, PD
X1D21	4C ³ 8B ⁷ 16A ¹⁵ 32A ³¹	I/O	IO, PD
X1D22	$X_0L3_{out}^4$ 1G ⁰	I/O	IO, PD
X1D23	1H ⁰	I/O	IO, PD
X1D24	1I ⁰	I/O	IO, PD
X1D25	1J ⁰	I/O	IO, PD
X1D26	tx_clk (rgmii) 4E ⁰ 8C ⁰ 16B ⁰	I/O	IOT, PD
X1D27	tx_ctl (rgmii) 4E ¹ 8C ¹ 16B ¹	I/O	IOT, PD
X1D28	rx_clk (rgmii) 4F ⁰ 8C ² 16B ²	I/O	IOT, PD
X1D29	rx_ctl (rgmii) 4F ¹ 8C ³ 16B ³	I/O	IOT, PD
X1D30	rx0 (rgmii) 4F ² 8C ⁴ 16B ⁴	I/O	IOT, PD
X1D31	rx1 (rgmii) 4F ³ 8C ⁵ 16B ⁵	I/O	IOT, PD
X1D32	rx2 (rgmii) 4E ² 8C ⁶ 16B ⁶	I/O	IOT, PD
X1D33	rx3 (rgmii) 4E ³ 8C ⁷ 16B ⁷	I/O	IOT, PD
X1D34	$X_0L0_{out}^2$ 1K ⁰	I/O	IO, PD
X1D35	$X_0L0_{out}^3$ 1L ⁰	I/O	IO, PD
X1D36	$X_0L0_{out}^4$ 1M ⁰ 8D ⁰ 16B ⁸	I/O	IO, PD
X1D37	$X_0L3_{in}^4$ 1N ⁰ 8D ¹ 16B ⁹	I/O	IO, PD
X1D38	$X_0L3_{in}^3$ 1O ⁰ 8D ² 16B ¹⁰	I/O	IO, PD
X1D39	$X_0L3_{in}^2$ 1P ⁰ 8D ³ 16B ¹¹	I/O	IO, PD
X1D40	tx3 (rgmii) 8D ⁴ 16B ¹²	I/O	IOT, PD
X1D41	tx2 (rgmii) 8D ⁵ 16B ¹³	I/O	IOT, PD
X1D42	tx1 (rgmii) 8D ⁶ 16B ¹⁴	I/O	IOT, PD
X1D43	tx0 (rgmii) 8D ⁷ 16B ¹⁵	I/O	IOT, PD
X1D49	$X_0L1_{in}^4$ 32A ⁰	I/O	IO, PD
X1D50	$X_0L1_{in}^3$ 32A ¹	I/O	IO, PD
X1D51	$X_0L1_{in}^2$ 32A ²	I/O	IO, PD
X1D52	$X_0L1_{in}^1$ 32A ³	I/O	IO, PD
X1D53	$X_0L1_{in}^0$ 32A ⁴	I/O	IO, PD
X1D54	$X_0L1_{out}^0$ 32A ⁵	I/O	IO, PD
X1D55	$X_0L1_{out}^1$ 32A ⁶	I/O	IO, PD
X1D56	$X_0L1_{out}^2$ 32A ⁷	I/O	IO, PD
X1D57	$X_0L1_{out}^3$ 32A ⁸	I/O	IO, PD
X1D58	$X_0L1_{out}^4$ 32A ⁹	I/O	IO, PD
X1D61	$X_0L2_{in}^4$ 32A ¹⁰	I/O	IO, PD
X1D62	$X_0L2_{in}^3$ 32A ¹¹	I/O	IO, PD
X1D63	$X_0L2_{in}^2$ 32A ¹²	I/O	IO, PD
X1D64	$X_0L2_{in}^1$ 32A ¹³	I/O	IO, PD
X1D65	$X_0L2_{in}^0$ 32A ¹⁴	I/O	IO, PD
X1D66	$X_0L2_{out}^0$ 32A ¹⁵	I/O	IO, PD

(continued)



Signal	Function	Type	Properties
X1D67	$X_0L2_{out}^1$ 32A ¹⁶	I/O	IO, PD
X1D68	$X_0L2_{out}^2$ 32A ¹⁷	I/O	IO, PD
X1D69	$X_0L2_{out}^3$ 32A ¹⁸	I/O	IO, PD
X1D70	$X_0L2_{out}^4$ 32A ¹⁹	I/O	IO, PD
X2D00	1A ⁰	I/O	IO, PD
X2D02	4A ⁰ 8A ⁰ 16A ⁰ 32A ²⁰	I/O	IO, PD
X2D03	4A ¹ 8A ¹ 16A ¹ 32A ²¹	I/O	IO, PD
X2D04	4B ⁰ 8A ² 16A ² 32A ²²	I/O	IO, PD
X2D05	4B ¹ 8A ³ 16A ³ 32A ²³	I/O	IO, PD
X2D06	4B ² 8A ⁴ 16A ⁴ 32A ²⁴	I/O	IO, PD
X2D07	4B ³ 8A ⁵ 16A ⁵ 32A ²⁵	I/O	IO, PD
X2D08	4A ² 8A ⁶ 16A ⁶ 32A ²⁶	I/O	IO, PD
X2D09	4A ³ 8A ⁷ 16A ⁷ 32A ²⁷	I/O	IO, PD
X2D11	1D ⁰	I/O	IO, PD
X2D12	1E ⁰	I/O	IO, PD
X2D13	1F ⁰	I/O	IO, PD
X2D14	4C ⁰ 8B ⁰ 16A ⁸ 32A ²⁸	I/O	IO, PD
X2D15	4C ¹ 8B ¹ 16A ⁹ 32A ²⁹	I/O	IO, PD
X2D16	$X_2L4_{in}^4$ 4D ⁰ 8B ² 16A ¹⁰	I/O	IO, PD
X2D17	$X_2L4_{in}^3$ 4D ¹ 8B ³ 16A ¹¹	I/O	IO, PD
X2D18	$X_2L4_{in}^2$ 4D ² 8B ⁴ 16A ¹²	I/O	IO, PD
X2D19	$X_2L4_{in}^1$ 4D ³ 8B ⁵ 16A ¹³	I/O	IO, PD
X2D20	4C ² 8B ⁶ 16A ¹⁴ 32A ³⁰	I/O	IO, PD
X2D21	4C ³ 8B ⁷ 16A ¹⁵ 32A ³¹	I/O	IO, PD
X2D22	1G ⁰	I/O	IO, PD
X2D23	1H ⁰	I/O	IO, PD
X2D24	$X_2L7_{in}^0$ 1I ⁰	I/O	IO, PD
X2D25	$X_2L7_{out}^0$ 1J ⁰	I/O	IO, PD
X2D26	$X_2L7_{out}^3$ 4E ⁰ 8C ⁰ 16B ⁰	I/O	IO, PD
X2D27	$X_2L7_{out}^4$ 4E ¹ 8C ¹ 16B ¹	I/O	IO, PD
X2D28	4F ⁰ 8C ² 16B ²	I/O	IO, PD
X2D29	4F ¹ 8C ³ 16B ³	I/O	IO, PD
X2D30	4F ² 8C ⁴ 16B ⁴	I/O	IO, PD
X2D31	4F ³ 8C ⁵ 16B ⁵	I/O	IO, PD
X2D32	4E ² 8C ⁶ 16B ⁶	I/O	IO, PD
X2D33	4E ³ 8C ⁷ 16B ⁷	I/O	IO, PD
X2D34	$X_2L7_{out}^1$ 1K ⁰	I/O	IO, PD
X2D35	$X_2L7_{out}^2$ 1L ⁰	I/O	IO, PD
X2D36	1M ⁰ 8D ⁰ 16B ⁸	I/O	IO, PD
X2D49	$X_2L5_{in}^4$ 32A ⁰	I/O	IO, PD
X2D50	$X_2L5_{in}^3$ 32A ¹	I/O	IO, PD
X2D51	$X_2L5_{in}^2$ 32A ²	I/O	IO, PD
X2D52	$X_2L5_{in}^1$ 32A ³	I/O	IO, PD

(continued)



Signal	Function	Type	Properties
X2D53	$X_2L5_{in}^0$	$32A^4$	I/O IO, PD
X2D54	$X_2L5_{out}^0$	$32A^5$	I/O IO, PD
X2D55	$X_2L5_{out}^1$	$32A^6$	I/O IO, PD
X2D56	$X_2L5_{out}^2$	$32A^7$	I/O IO, PD
X2D57	$X_2L5_{out}^3$	$32A^8$	I/O IO, PD
X2D58	$X_2L5_{out}^4$	$32A^9$	I/O IO, PD
X2D61	$X_2L6_{in}^4$	$32A^{10}$	I/O IO, PD
X2D62	$X_2L6_{in}^3$	$32A^{11}$	I/O IO, PD
X2D63	$X_2L6_{in}^2$	$32A^{12}$	I/O IO, PD
X2D64	$X_2L6_{in}^1$	$32A^{13}$	I/O IO, PD
X2D65	$X_2L6_{in}^0$	$32A^{14}$	I/O IO, PD
X2D66	$X_2L6_{out}^0$	$32A^{15}$	I/O IO, PD
X2D67	$X_2L6_{out}^1$	$32A^{16}$	I/O IO, PD
X2D68	$X_2L6_{out}^2$	$32A^{17}$	I/O IO, PD
X2D69	$X_2L6_{out}^3$	$32A^{18}$	I/O IO, PD
X2D70	$X_2L6_{out}^4$	$32A^{19}$	I/O IO, PD
X3D00	$X_2L7_{in}^2$	$1A^0$	I/O IO, PD
X3D01	$X_2L7_{in}^1$	$1B^0$	I/O IO, PD
X3D02	$X_2L4_{in}^0$	$4A^0$ $8A^0$ $16A^0$ $32A^{20}$	I/O IO, PD
X3D03	$X_2L4_{out}^0$	$4A^1$ $8A^1$ $16A^1$ $32A^{21}$	I/O IO, PD
X3D04	$X_2L4_{out}^1$	$4B^0$ $8A^2$ $16A^2$ $32A^{22}$	I/O IO, PD
X3D05	$X_2L4_{out}^2$	$4B^1$ $8A^3$ $16A^3$ $32A^{23}$	I/O IO, PD
X3D06	$X_2L4_{out}^3$	$4B^2$ $8A^4$ $16A^4$ $32A^{24}$	I/O IO, PD
X3D07	$X_2L4_{out}^4$	$4B^3$ $8A^5$ $16A^5$ $32A^{25}$	I/O IO, PD
X3D08	$X_2L7_{in}^4$	$4A^2$ $8A^6$ $16A^6$ $32A^{26}$	I/O IO, PD
X3D09	$X_2L7_{in}^3$	$4A^3$ $8A^7$ $16A^7$ $32A^{27}$	I/O IO, PD
X3D10	$1C^0$		I/O IOT, PD
X3D11	$1D^0$		I/O IOT, PD
X3D12	$1E^0$		I/O IO, PD
X3D13	$1F^0$		I/O IO, PD
X3D14		$4C^0$ $8B^0$ $16A^8$ $32A^{28}$	I/O IO, PD
X3D15		$4C^1$ $8B^1$ $16A^9$ $32A^{29}$	I/O IO, PD
X3D20		$4C^2$ $8B^6$ $16A^{14}$ $32A^{30}$	I/O IO, PD
X3D21		$4C^3$ $8B^7$ $16A^{15}$ $32A^{31}$	I/O IO, PD
X3D23	$1H^0$		I/O IO, PD
X3D24	$1I^0$		I/O IO, PD
X3D25	$1J^0$		I/O IO, PD
X3D26	tx_clk (rgmii)	$4E^0$ $8C^0$ $16B^0$	I/O IOT, PD
X3D27	tx_ctl (rgmii)	$4E^1$ $8C^1$ $16B^1$	I/O IOT, PD
X3D28	rx_clk (rgmii)	$4F^0$ $8C^2$ $16B^2$	I/O IOT, PD
X3D29	rx_ctl (rgmii)	$4F^1$ $8C^3$ $16B^3$	I/O IOT, PD
X3D30	rx0 (rgmii)	$4F^2$ $8C^4$ $16B^4$	I/O IOT, PD
X3D31	rx1 (rgmii)	$4F^3$ $8C^5$ $16B^5$	I/O IOT, PD

(continued)



Signal	Function	Type	Properties
X3D32	rx2 (rgmii) 4E ² 8C ⁶ 16B ⁶	I/O	IOT, PD
X3D33	rx3 (rgmii) 4E ³ 8C ⁷ 16B ⁷	I/O	IOT, PD
X3D40	tx3 (rgmii) 8D ⁴ 16B ¹²	I/O	IOT, PD
X3D41	tx2 (rgmii) 8D ⁵ 16B ¹³	I/O	IOT, PD
X3D42	tx1 (rgmii) 8D ⁶ 16B ¹⁴	I/O	IOT, PD
X3D43	tx0 (rgmii) 8D ⁷ 16B ¹⁵	I/O	IOT, PD

System pins (4)			
Signal	Function	Type	Properties
CLK	PLL reference clock	Input	IO, PD, ST
DEBUG_N	Multi-chip debug, active low	I/O	IO, PU
MODE0	Boot mode select	Input	PU
MODE1	Boot mode select	Input	PU

5 Example Application Diagram

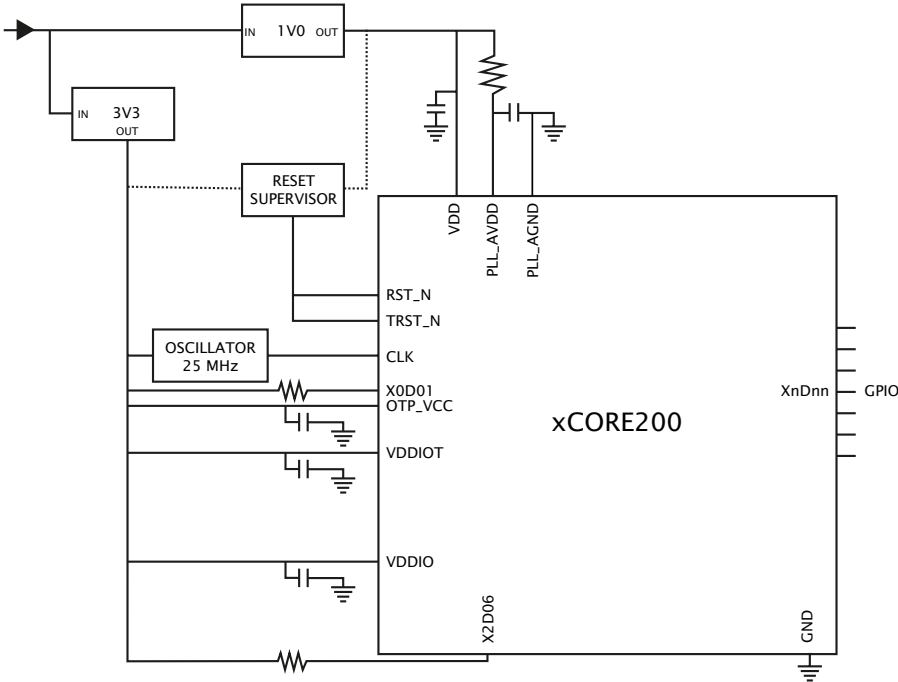

Figure 2:
Simplified
Reference
Schematic

► see Section 11 for details on the power supplies and PCB design



6 Product Overview

The XLF224-512-FB374 is a powerful device that consists of four xCORE Tiles, each comprising a flexible logical processing cores with tightly integrated I/O and on-chip memory.

6.1 Logical cores

Each tile has 6 active logical cores, which issue instructions down a shared five-stage pipeline. Instructions from the active cores are issued round-robin. If up to five logical cores are active, each core is allocated a fifth of the processing cycles. If more than five logical cores are active, each core is allocated at least $\frac{1}{n}$ cycles (for n cores). Figure 3 shows the guaranteed core performance depending on the number of cores used.

Figure 3:
Logical core
performance

Speed grade	MIPS	Frequency	Minimum MIPS per core (for n cores)							
			1	2	3	4	5	6		
20	2000 MIPS	500 MHz	100	100	100	100	100	83		

There is no way that the performance of a logical core can be reduced below these predicted levels (unless *priority threads* are used: in this case the guaranteed minimum performance is computed based on the number of priority threads as defined in the architecture manual). Because cores may be delayed on I/O, however, their unused processing cycles can be taken by other cores. This means that for more than five logical cores, the performance of each core is often higher than the predicted minimum but cannot be guaranteed.

The logical cores are triggered by events instead of interrupts and run to completion. A logical core can be paused to wait for an event.

6.2 xTIME scheduler

The xTIME scheduler handles the events generated by xCORE Tile resources, such as channel ends, timers and I/O pins. It ensures that all events are serviced and synchronized, without the need for an RTOS. Events that occur at the I/O pins are handled by the Hardware-Response ports and fed directly to the appropriate xCORE Tile. An xCORE Tile can also choose to wait for a specified time to elapse, or for data to become available on a channel.

Tasks do not need to be prioritised as each of them runs on their own logical xCORE. It is possible to share a set of low priority tasks on a single core using cooperative multi-tasking.

6.3 Hardware Response Ports

Hardware Response ports connect an xCORE tile to one or more physical pins and as such define the interface between hardware attached to the XLF224-512-FB374, and the software running on it. A combination of 1bit, 4bit, 8bit, 16bit and 32bit ports are available. All pins of a port provide either output or input. Signals in different directions cannot be mapped onto the same port.

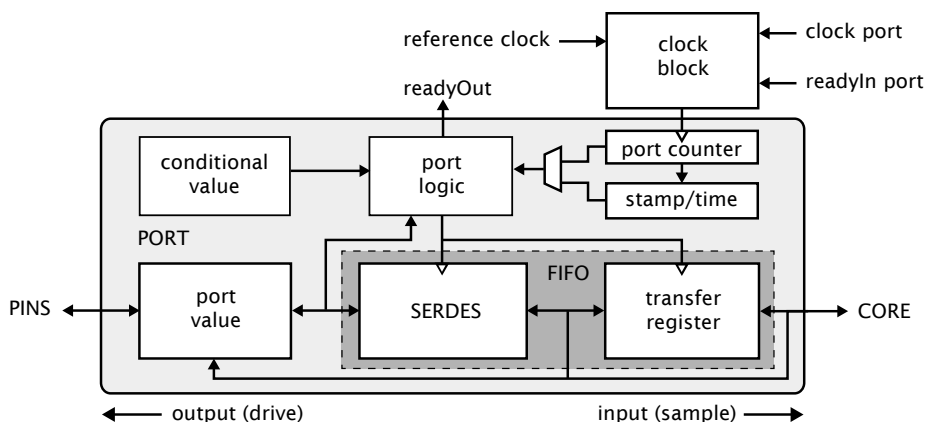

Figure 4:
Port block
diagram

The port logic can drive its pins high or low, or it can sample the value on its pins, optionally waiting for a particular condition. Ports are accessed using dedicated instructions that are executed in a single processor cycle. xCORE200 IO pins can be used as *open collector* outputs, where signals are driven low if a zero is output, but left high impedance if a one is output. This option is set on a per-port basis.

Data is transferred between the pins and core using a FIFO that comprises a SERDES and transfer register, providing options for serialization and buffered data.

Each port has a 16-bit counter that can be used to control the time at which data is transferred between the port value and transfer register. The counter values can be obtained at any time to find out when data was obtained, or used to delay I/O until some time in the future. The port counter value is automatically saved as a timestamp, that can be used to provide precise control of response times.

The ports and xCONNECT links are multiplexed onto the physical pins. If an xConnect Link is enabled, the pins of the underlying ports are disabled. If a port is enabled, it overrules ports with higher widths that share the same pins. The pins on the wider port that are not shared remain available for use when the narrower port is enabled. Ports always operate at their specified width, even if they share pins with another port.

6.4 Clock blocks

xCORE devices include a set of programmable clocks called clock blocks that can be used to govern the rate at which ports execute. Each xCORE tile has six clock blocks: the first clock block provides the tile reference clock and runs at a default frequency of 100MHz; the remaining clock blocks can be set to run at different frequencies.

A clock block can use a 1-bit port as its clock source allowing external application clocks to be used to drive the input and output interfaces. xCORE200 clock blocks optionally divide the clock input from a 1-bit port.

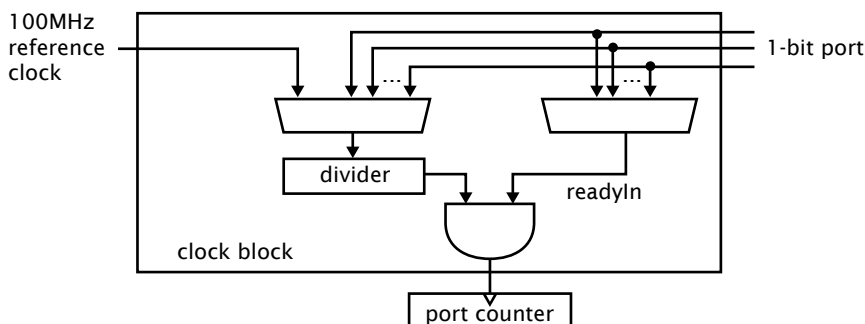

Figure 5:
Clock block
diagram

In many cases I/O signals are accompanied by strobing signals. The xCORE ports can input and interpret strobe (known as readyIn and readyOut) signals generated by external sources, and ports can generate strobe signals to accompany output data.

On reset, each port is connected to clock block 0, which runs from the xCORE Tile reference clock.

6.5 Channels and Channel Ends

Logical cores communicate using point-to-point connections, formed between two channel ends. A channel-end is a resource on an xCORE tile, that is allocated by the program. Each channel-end has a unique system-wide identifier that comprises a unique number and their tile identifier. Data is transmitted to a channel-end by an output-instruction; and the other side executes an input-instruction. Data can be passed synchronously or asynchronously between the channel ends.

6.6 xCONNECT Switch and Links

XMOS devices provide a scalable architecture, where multiple xCORE devices can be connected together to form one system. Each xCORE device has an xCONNECT interconnect that provides a communication infrastructure for all tasks that run on the various xCORE tiles on the system.

The interconnect relies on a collection of switches and XMOS links. Each xCORE device has an on-chip switch that can set up circuits or route data. The switches are connected by xConnect Links. An XMOS link provides a physical connection between two switches. The switch has a routing algorithm that supports many different topologies, including lines, meshes, trees, and hypercubes.

The links operate in either 2 wires per direction or 5 wires per direction mode, depending on the amount of bandwidth required. Circuit switched, streaming and packet switched data can both be supported efficiently. Streams provide the fastest possible data rates between xCORE Tiles (up to 250 MBit/s), but each stream requires a single link to be reserved between switches on two tiles. All packet communications can be multiplexed onto a single link.

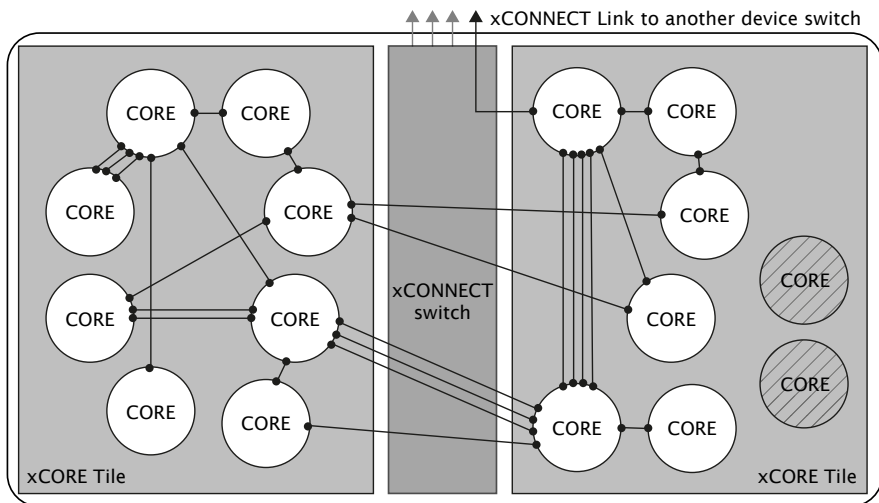

Figure 6:
Switch, links
and channel
ends

Information on the supported routing topologies that can be used to connect multiple devices together can be found in the XS1-LF Link Performance and Design Guide, [X2999](#).

7 PLL

The PLL creates a high-speed clock that is used for the switch, tile, and reference clock. The PLL multiplication value is selected through the two MODE pins, and can be changed by software to speed up the tile or use less power. The MODE pins are set as shown in Figure 7:

Oscillator Frequency	MODE		Tile Boot Frequency	PLL Ratio	PLL settings		
	1	0			OD	F	R
3.25-10 MHz	0	0	130-400 MHz	40	1	159	0
9-25 MHz	1	1	144-400 MHz	16	1	63	0
25-50 MHz	1	0	167-400 MHz	8	1	31	0
50-100 MHz	0	1	196-400 MHz	4	1	15	0

Figure 7:
PLL multiplier
values and
MODE pins

Figure 7 also lists the values of *OD*, *F* and *R*, which are the registers that define the ratio of the tile frequency to the oscillator frequency:

$$F_{core} = F_{osc} \times \frac{F+1}{2} \times \frac{1}{R+1} \times \frac{1}{OD+1}$$

OD, *F* and *R* must be chosen so that $0 \leq R \leq 63$, $0 \leq F \leq 4095$, $0 \leq OD \leq 7$, and $260MHz \leq F_{osc} \times \frac{F+1}{2} \times \frac{1}{R+1} \leq 1.3GHz$. The *OD*, *F*, and *R* values can be modified by writing to the digital node PLL configuration register.

The MODE pins must be held at a static value during and after deassertion of the system reset.

If a different tile frequency is required (eg, 500 MHz), then the PLL must be reprogrammed after boot to provide the required tile frequency. The XMOS tools perform this operation by default. Further details on configuring the clock can be found in the xCORE-200 Clock Frequency Control document.

8 Boot Procedure

The device is kept in reset by driving RST_N low. When in reset, all GPIO pins have a pull-down enabled. The processor must be held in reset until VDDIOL is in spec for at least 1 ms. When the device is taken out of reset by releasing RST_N the processor starts its internal reset process. After 15-150 μ s (depending on the input clock) the processor boots.

Pin X2D06 must be pulled high with an external pull-up whilst the chip comes out of reset, to ensure that tile 2 will boot from link. X2D04, X2D05, and X2D07 should be kept low whilst the chip comes out of reset.

The device boots from a QSPI flash (IS25LP016D) that is embedded in the device. The QSPI flash is connected to the ports on Tile 0 as shown in Figure 8. An external 1K resistor must connect X0D01 to VDDIOL. X0D10 should ideally not be connected. If X0D10 is connected, then a 150 ohm series resistor close to the device is recommended. X0D04..X0D07 should be not connected.

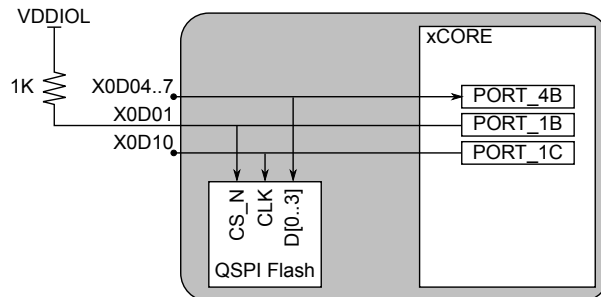

Figure 8:
QSPI port
connectivity

The xCORE Tile boot procedure is illustrated in Figure 9. If bit 5 of the security register (see §9.1) is set, the device boots from OTP. Otherwise, the device boots from the internal flash.

The boot image has the following format:

- ▶ A 32-bit program size s in words.
- ▶ Program consisting of $s \times 4$ bytes.
- ▶ A 32-bit CRC, or the value 0x0D15AB1E to indicate that no CRC check should be performed.

The program size and CRC are stored least significant byte first. The program is loaded into the lowest memory address of RAM, and the program is started from that address. The CRC is calculated over the byte stream represented by the program size and the

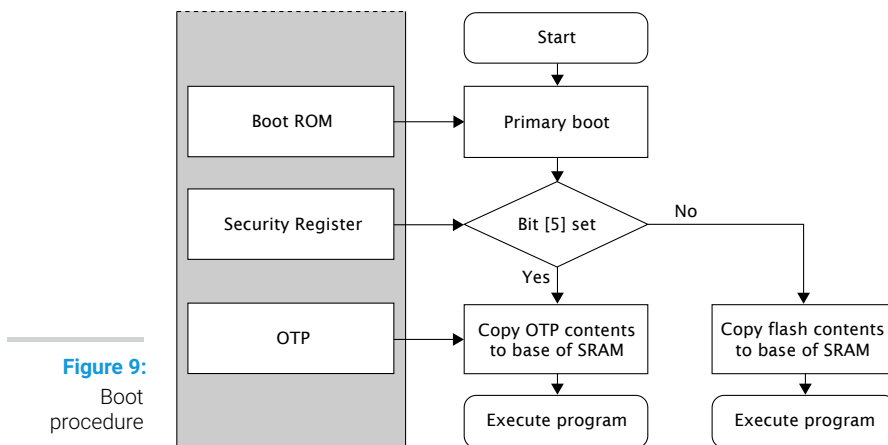

program itself. The polynomial used is 0xEDB88320 (IEEE 802.3); the CRC register is initialized with 0xFFFFFFFF and the residue is inverted to produce the CRC.

8.1 Security register

The security register enables security features on the xCORE tile. The features shown in Figure 10 provide a strong level of protection and are sufficient for providing strong IP security.

9 Memory

9.1 OTP

Each xCORE Tile integrates 8 KB one-time programmable (OTP) memory along with a security register that configures system wide security features. The OTP holds data in four sectors each containing 512 rows of 32 bits which can be used to implement secure bootloaders and store encryption keys. Data for the security register is loaded from the OTP on power up. All additional data in OTP is copied from the OTP to SRAM and executed first on the processor.

The OTP memory is programmed using three special I/O ports: the OTP address port is a 16-bit port with resource ID 0x100200, the OTP data is written via a 32-bit port with resource ID 0x200100, and the OTP control is on a 16-bit port with ID 0x100300. Programming is performed through `libotp` and `xburn`.

9.2 SRAM

Each xCORE Tile integrates a single 128KB SRAM bank for both instructions and data. All internal memory is 32 bits wide, and instructions are either 16-bit or 32-bit. Byte (8-bit), half-word (16-bit) or word (32-bit) accesses are supported and are executed within one tile clock cycle. There is no dedicated external memory interface, although data memory can be expanded through appropriate use of the ports.

Feature	Bit	Description
Disable JTAG	0	The JTAG interface is disabled, making it impossible for the tile state or memory content to be accessed via the JTAG interface.
Disable Link access	1	Other tiles are forbidden access to the processor state via the system switch. Disabling both JTAG and Link access transforms an xCORE Tile into a “secure island” with other tiles free for non-secure user application code.
Secure Boot	5	The xCORE Tile is forced to boot from address 0 of the OTP, allowing the xCORE Tile boot ROM to be bypassed (see §8).
Redundant rows	7	Enables redundant rows in OTP.
Sector Lock 0	8	Disable programming of OTP sector 0.
Sector Lock 1	9	Disable programming of OTP sector 1.
Sector Lock 2	10	Disable programming of OTP sector 2.
Sector Lock 3	11	Disable programming of OTP sector 3.
OTP Master Lock	12	Disable OTP programming completely: disables updates to all sectors and security register.
Disable JTAG-OTP	13	Disable all (read & write) access from the JTAG interface to this OTP.
Disable Global Debug	14	Disables access to the DEBUG_N pin.
	21..15	General purpose software accessible security register available to end-users.
	31..22	General purpose user programmable JTAG UserID code extension.

Figure 10:
Security register features

10 JTAG

The JTAG module can be used for loading programs, boundary scan testing, in-circuit source-level debugging and programming the OTP memory.

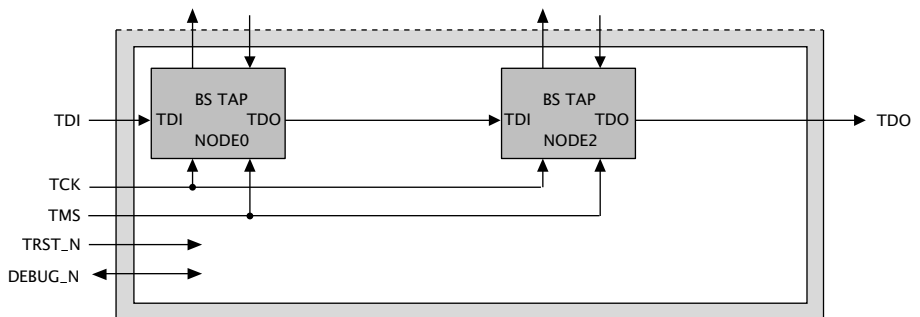

Figure 11:
JTAG chain structure

The JTAG chain structure is illustrated in Figure 11. It comprises two 1149.1 compliant TAPs that can be used for boundary scan of the I/O pins. Each tap has a 4-bit IR and



32-bit DR. It also provides access to a chip TAP that in turn can access the xCORE Tile for loading code and debugging.

The TRST_N pin must be asserted low during and after power up for 100 ns. If JTAG is not required, the TRST_N pin can be tied to ground to hold the JTAG module in reset.

The DEBUG_N pin is used to synchronize the debugging of multiple xCORE Tiles. This pin can operate in both output and input mode. In output mode and when configured to do so, DEBUG_N is driven low by the device when the processor hits a debug break point. Prior to this point the pin will be tri-stated. In input mode and when configured to do so, driving this pin low will put the xCORE Tile into debug mode. Software can set the behavior of the xCORE Tile based on this pin. This pin should have an external pull up of 4K7-47K Ω or left not connected in single core applications.

The JTAG device identification register can be read by using the IDCODE instruction. Its contents are specified in Figure 12.

Figure 12:
IDCODE return value

Device Identification Register																																				
Version		Part Number										Manufacturer Identity										Bit0														
0	0	0	0	0	0	0	0	0	0	0	0	0	0	0	0	0	0	1	0	1	1	0	0	0	1	1	0	0	1	1	0	0	1	1		
0		0				0		0				5		6		3		3																		1

The JTAG usercode register can be read by using the USERCODE instruction. Its contents are specified in Figure 13. The OTP User ID field is read from bits [22:31] of the security register on xCORE Tile 0, see §9.1 (all zero on unprogrammed devices).

Figure 13:
USERCODE return value

Usercode Register																																								
OTP User ID										Unused				Silicon Revision																		Bit0								
0	0	0	0	0	0	0	0	0	0	0	0	0	0	0	0	0	0	0	1	0	1	0	0	0	0	0	0	0	0	0	0	0	0	0	0	0	0	0		
0										0				2		8		0		0																				0

11 Board Integration

The device has the following power supply pins:

- ▶ VDD pins for the xCORE Tile
- ▶ VDDIO pins for the I/O lines
- ▶ PLL_AVDD pins for the PLL
- ▶ OTP_VCC pins for the OTP

Several pins of each type are provided to minimize the effect of inductance within the package, all of which must be connected. The power supplies must be brought up monotonically and input voltages must not exceed specification at any time.

VDDIO/OTP_VCC and VDD can ramp up independently. In order to reduce stresses on the device, it is preferable to make them ramp up in a short time frame of each other, no more than 50 ms apart. RST_N and TRST_N should be kept low until all power supplies are stable and within tolerances of their final voltage. RST_N should be at least 1 ms after VDDIO good to enable the built-in flash to settle. Power sequencing is summarised in Figure 14

Figure 14:
Sequencing of
power
supplies and
RST_N

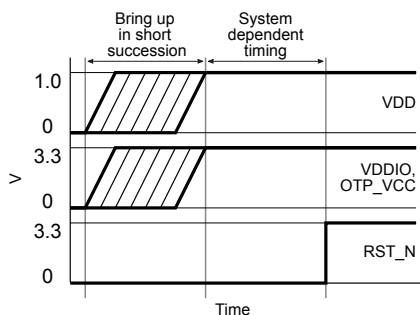

The PLL_AVDD supply should be separated from the other noisier supplies on the board. The PLL requires a very clean power supply, and a low pass filter (for example, a 2.2Ω resistor and 100 nF multi-layer ceramic capacitor) is recommended on this pin.

The following ground pins are provided:

- ▶ PLL_AGND for PLL_AVDD
- ▶ GND for all other supplies

All ground pins must be connected directly to the board ground.

The VDD and VDDIO supplies should be decoupled close to the chip by several 100 nF low inductance multi-layer ceramic capacitors between the supplies and GND (for example, 100nF 0402 for every other supply pin). The ground side of the decoupling capacitors should have as short a path back to the GND pins as possible. A bulk decoupling capacitor of at least 10 μF should be placed on each of these supplies.

RST_N is an active-low asynchronous-assertion global reset signal. Following a reset, the PLL re-establishes lock after which the device boots up according to the boot mode (see §3). RST_N must be asserted low during and after power up for 100 ns.

11.1 Land patterns and solder stencils

The package is a 374 ball Fine Ball Grid Array (FBGA) on a 0.8 mm pitch.

The land patterns and solder stencils will depend on the PCB manufacturing process. We recommend you design them with using the IPC specifications “*Generic Requirements for Surface Mount Design and Land Pattern Standards*” IPC-7351B. This standard aims to achieve desired targets of heel, toe and side fillets for solder-joints. The mechanical drawings in Section 13 specify the dimensions and tolerances.

11.2 Ground and Thermal Vias

Vias next to each ground ball into the ground plane of the PCB are recommended for a low inductance ground connection and good thermal performance.

11.3 Moisture Sensitivity

XMOS devices are, like all semiconductor devices, susceptible to moisture absorption. When removed from the sealed packaging, the devices slowly absorb moisture from the surrounding environment. If the level of moisture present in the device is too high during reflow, damage can occur due to the increased internal vapour pressure of moisture. Example damage can include bond wire damage, die lifting, internal or external package cracks and/or delamination.

All XMOS devices are Moisture Sensitivity Level (MSL) 3 - devices have a shelf life of 168 hours between removal from the packaging and reflow, provided they are stored below 30C and 60% RH. If devices have exceeded these values or an included moisture indicator card shows excessive levels of moisture, then the parts should be baked as appropriate before use. This is based on information from *Joint IPC/JEDEC Standard For Moisture/Reflow Sensitivity Classification For Nonhermetic Solid State Surface-Mount Devices J-STD-020* Revision D.

12 Electrical Characteristics

12.1 Absolute Maximum Ratings

Stresses beyond those listed under Absolute Maximum Ratings may cause permanent damage to the device. Exposure to any Absolute Maximum Rating condition for extended periods may affect device reliability and lifetime.

Symbol	Parameter	MIN	MAX	UNITS	Notes
VDD	Tile DC supply voltage	-0.2	1.1	V	
PLL_AVDD	PLL analog supply	-0.2	1.1	V	
VDDIO	I/O supply voltage	-0.3	3.75	V	
OTP_VCC	OTP supply voltage	-0.3	3.75	V	
Tj	Junction temperature		125	°C	
Tstg	Storage temperature	-65	150	°C	
V(Vin)	Voltage applied to any IO pin	-0.3	3.75	V	
I(XxDxx)	GPIO current	-30	30	mA	
V(X0D03-8)	Voltage applied to flash pins	-0.3	VDDIO+0.5	V	
I(VDDIO)	Current for VDDIO domain		2064	mA	A, B, C
I(VDDIOT)	Current for VDDIOT domain		98	mA	A, C

Figure 15:
Absolute maximum ratings

A Exceeding these current limits will result in premature aging and reduced lifetime.

B This current consumption must be evenly distributed over all VDDIO pins.

C All main power (VDD, VDDIO) and ground (VSS) pins must always be connected.

12.2 Operating Conditions

Symbol	Parameter	MIN	TYP	MAX	UNITS	Notes
VDD	Tile DC supply voltage	0.95	1.00	1.05	V	
VDDIO	I/O supply voltage	2.30	3.30	3.60	V	
VDDIOT_0	I/O supply voltage	2.25	3.30	3.60	V	
VDDIOT_1	I/O supply voltage	2.25	3.30	3.60	V	
USB_VDD	USB tile DC supply voltage	0.95	1.00	1.05	V	
VDD33	Peripheral supply	3.135	3.30	3.465	V	
PLL_AVDD	PLL analog supply	0.95	1.00	1.05	V	
Cl	xCORE Tile I/O load capacitance			25	pF	
Ta	Ambient operating temperature ()	0		70	°C	
	Ambient operating temperature ()	-40		85	°C	
Tj	Junction temperature			125	°C	

Figure 16:
Operating conditions

12.3 DC Characteristics, VDDIO=3V3

Symbol	Parameter	MIN	TYP	MAX	UNITS	Notes
V(IH)	Input high voltage	2.00		3.60	V	A
V(IL)	Input low voltage	-0.30		0.70	V	A
V(OH)	Output high voltage	2.20			V	B, C
V(OL)	Output low voltage			0.40	V	B, C
I(PU)	Internal pull-up current (Vin=0V)	-100			μA	D
I(PD)	Internal pull-down current (Vin=3.3V)			100	μA	D
I(LC)	Input leakage current	-10		10	μA	

Figure 17:
DC characteristics

A All pins except power supply pins.

B Pins X1D40, X1D41, X1D42, X1D43, X1D26, X1D27, X3D40, X3D41, X3D42, X3D43, X3D26, and X3D27 are nominal 8 mA drivers, the remainder of the general-purpose I/Os are 4 mA.

C Measured with 4 mA drivers sourcing 4 mA, 8 mA drivers sourcing 8 mA.

D Used to guarantee logic state for an I/O when high impedance. The internal pull-ups/pull-downs should not be used to pull external circuitry. In order to pull the pin to the opposite state, a 4K7 resistor is recommended to D overcome the internal pull current.

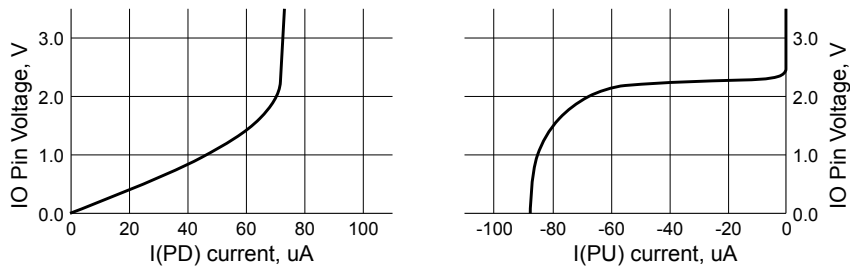

Figure 18:
Typical internal pull-down and pull-up currents

12.4 ESD Stress Voltage

Figure 19:
ESD stress voltage

Symbol	Parameter	MIN	TYP	MAX	UNITS	Notes
HBM	Human body model	-2.00		2.00	KV	
CDM	Charged Device Model	-500		500	V	

12.5 Reset Timing

Figure 20:
Reset timing

Symbol	Parameters	MIN	TYP	MAX	UNITS	Notes
T(RST)	Reset pulse width	5			μs	
T(INIT)	Initialization time			150	μs	A

A Shows the time taken to start booting after RST_N has gone high.

12.6 Power Consumption

Figure 21:
xCORE Tile
currents

Symbol	Parameter	MIN	TYP	MAX	UNITS	Notes
I(DDCQ)	Quiescent VDD current		45		mA	A, B, C
PD	Tile power dissipation		325		μW/MIPS	A, D, E, F
IDD	Active VDD current		1140	1400	mA	A, G
I(ADDPLL)	PLL_AVDD current		10	14	mA	H

A Use for budgetary purposes only.

B Assumes typical tile and I/O voltages with no switching activity.

C Includes PLL current.

D Assumes typical tile and I/O voltages with nominal switching activity.

E Assumes 1 MHz = 1 MIPS.

F PD(TYP) value is the usage power consumption under typical operating conditions.

G Measurement conditions: VDD = 1.0 V, VDDIO = 3.3 V, 25 °C, 500 MHz, average device resource usage.

H PLL_AVDD = 1.0 V



The tile power consumption of the device is highly application dependent and should be used for budgetary purposes only.

More detailed power analysis can be found in the xCORE-200 Power Consumption document,

12.7 Clock

Figure 22:
Clock

Symbol	Parameter	MIN	TYP	MAX	UNITS	Notes
f	Frequency	3.25	25	100	MHz	
SR	Slew rate	0.10			V/ns	
TJ(LT)	Long term jitter (pk-pk)			2	%	A
f(MAX)	Processor clock frequency			500	MHz	B

A Percentage of CLK period.

B Assumes typical tile and I/O voltages with nominal activity.

Further details can be found in the xCORE-200 Clock Frequency Control document,

12.8 xCORE Tile I/O AC Characteristics

Figure 23:
I/O AC charac-
teristics

Symbol	Parameter	MIN	TYP	MAX	UNITS	Notes
T(XOVALID)	Input data valid window	8			ns	
T(XOINVALID)	Output data invalid window	9			ns	
T(XIFMAX)	Rate at which data can be sampled with respect to an external clock			60	MHz	

The input valid window parameter relates to the capability of the device to capture data input to the chip with respect to an external clock source. It is calculated as the sum of the input setup time and input hold time with respect to the external clock as measured at the pins. The output invalid window specifies the time for which an output is invalid with respect to the external clock. Note that these parameters are specified as a win-

dow rather than absolute numbers since the device provides functionality to delay the incoming clock with respect to the incoming data.

Information on interfacing to high-speed synchronous interfaces can be found in the Port I/O Timing document, [X5821](#).

12.9 xConnect Link Performance

Figure 24:
Link
performance

Symbol	Parameter	MIN	TYP	MAX	UNITS	Notes
B(2blinkP)	2b link bandwidth (packetized)			87	MBit/s	A, B
B(5blinkP)	5b link bandwidth (packetized)			217	MBit/s	A, B
B(2blinkS)	2b link bandwidth (streaming)			100	MBit/s	B
B(5blinkS)	5b link bandwidth (streaming)			250	MBit/s	B

Assumes 32-byte packet in 3-byte header mode. Actual performance depends on size of the header and A payload.

B 7.5 ns symbol time.

The asynchronous nature of links means that the relative phasing of CLK clocks is not important in a multi-clock system, providing each meets the required stability criteria.

12.10 JTAG Timing

Figure 25:
JTAG timing

Symbol	Parameter	MIN	TYP	MAX	UNITS	Notes
f(TCK_D)	TCK frequency (debug)			18	MHz	
f(TCK_B)	TCK frequency (boundary scan)			10	MHz	
T(SETUP)	TDO to TCK setup time	5			ns	A
T(HOLD)	TDO to TCK hold time	5			ns	A
T(DELAY)	TCK to output delay			15	ns	B

A Timing applies to TMS and TDI inputs.

B Timing applies to TDO output from negative edge of TCK.

All JTAG operations are synchronous to TCK apart from the global asynchronous reset TRST_N.

13 Package Information

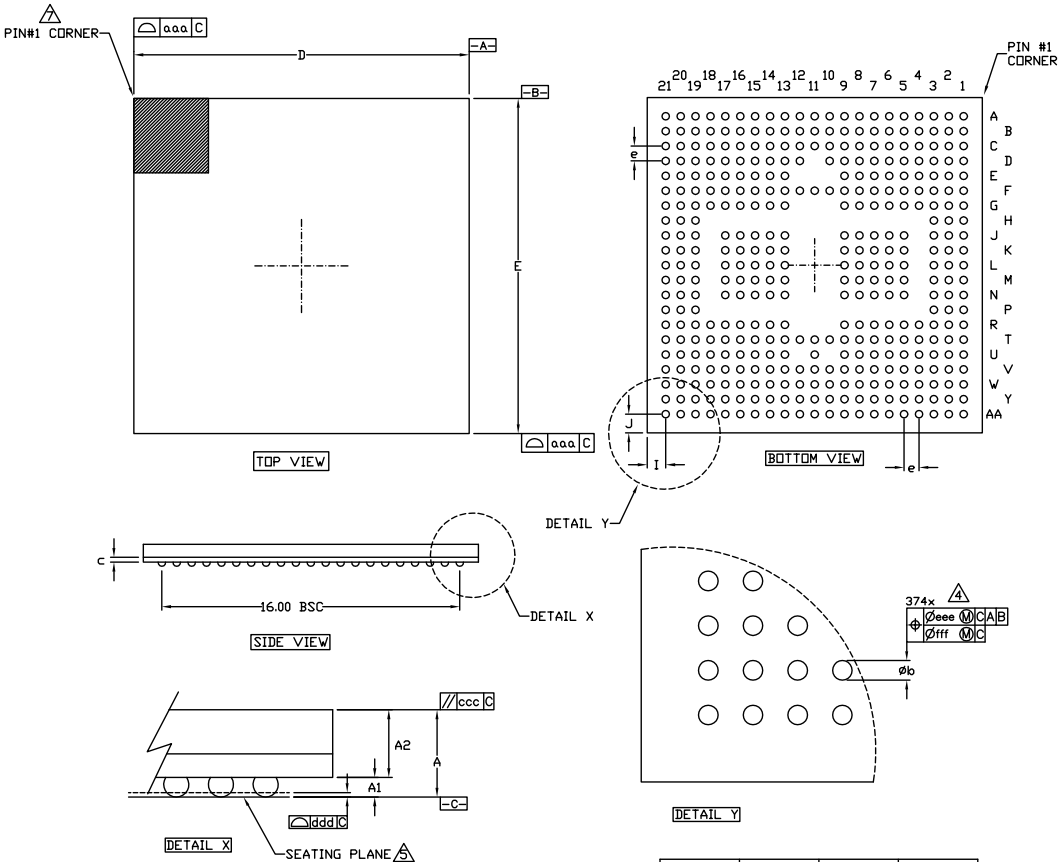

NOTE:

1. ALL DIMENSIONS ARE IN MILLIMETERS.
2. "e" REPRESENTS THE BASIC SOLDER BALL GRID PITCH.
3. "M" REPRESENTS THE MAXIMUM SOLDER BALL MATRIX SIZE.
4. DIMENSIONS "b" IS MEASURED AT THE MAXIMUM SOLDER BALL DIAMETER PARALLEL TO PRIMARY DATUM ---C--- .
5. PRIMARY DATUM ---C--- AND SEATING PLANE ---A--- ARE DESIGNED BY THE SPHERICAL CROWNS OF THE SOLDER BALLS.
6. DIMENSIONING AND TOLERANCING PER ASME Y14.5M-1994
7. ---A1--- CORNER MUST BE IDENTIFIED BY LASER MARK.

SYMBOL	MIN.	NOM.	MAX.
A	1.16	1.26	1.36
A1	0.25	0.30	0.35
A2	0.91	0.96	1.01
D	17.90	18.00	18.10
E	17.90	18.00	18.10
I	1.00 REF.		
J	1.00 REF.		
M	21x21<DEPOPULATED>		
aaa			0.15
ccc			0.20
ddd			0.10
eee			0.15
fff			0.08
b	0.35	0.40	0.45
e	0.80 BSC.		
c	0.26 REF.		



13.1 Part Marking

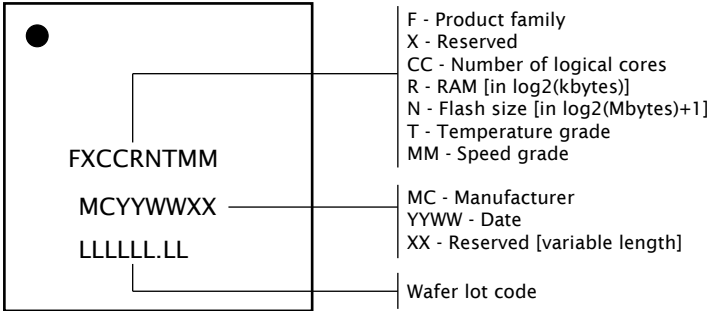

Figure 26:
Part marking scheme

14 Ordering Information

Figure 27:
Orderable part numbers

Product Code	Marking	Qualification	Speed Grade
XLF224-512-FB374-C40A	L12492C40	Commercial	2000 MIPS
XLF224-512-FB374-I40A	L12492C40	Industrial	2000 MIPS



Appendices

A Configuration of the XLF224-512-FB374

The device is configured through banks of registers, as shown in Figure 28.

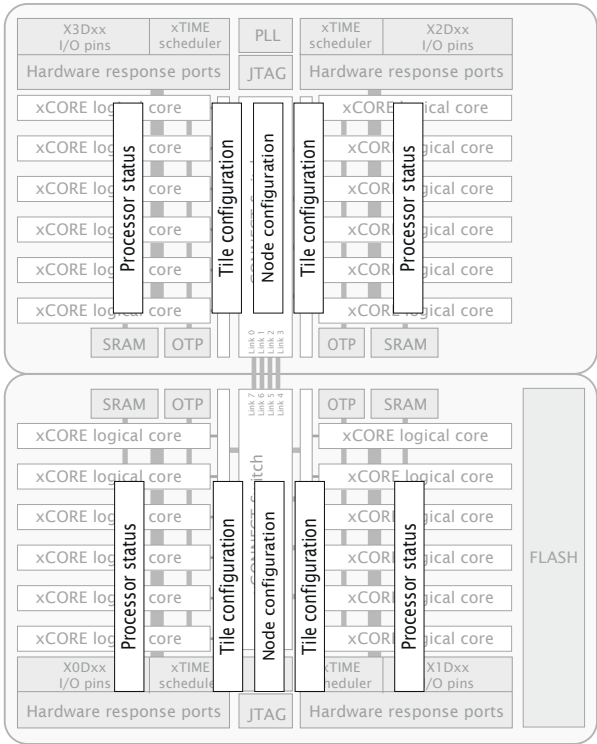

Figure 28: Registers

The following communication sequences specify how to access those registers. Any messages transmitted contain the most significant 24 bits of the channel-end to which a response is to be sent. This comprises the node-identifier and the channel number within the node. If no response is required on a write operation, supply 24-bits with the last 8-bits set, which suppresses the reply message. Any multi-byte data is sent most significant byte first.

A.1 Accessing a processor status register

The processor status registers are accessed directly from the processor instruction set. The instructions GETPS and SETPS read and write a word. The register number should be translated into a processor-status resource identifier by shifting the register number left 8 places, and ORing it with 0x0B. Alternatively, the functions `getps(reg)` and `setps(↔ reg, value)` can be used from XC.



A.2 Accessing an xCORE Tile configuration register

xCORE Tile configuration registers can be accessed through the interconnect using the functions `write_tile_config_reg(tile_ref, ...)` and `read_tile_config_reg(tile_ref, ↵ ...)`, where `tile_ref` is the name of the xCORE Tile, e.g. `tile[1]`. These functions implement the protocols described below.

Instead of using the functions above, a channel-end can be allocated to communicate with the xCORE tile configuration registers. The destination of the channel-end should be set to `0xnnnnC20c` where `nnnnn` is the tile-identifier.

A write message comprises the following:

control-token 192	24-bit response channel-end identifier	16-bit register number	32-bit data	control-token 1
----------------------	---	---------------------------	----------------	--------------------

The response to a write message comprises either control tokens 3 and 1 (for success), or control tokens 4 and 1 (for failure).

A read message comprises the following:

control-token 193	24-bit response channel-end identifier	16-bit register number	control-token 1
----------------------	---	---------------------------	--------------------

The response to the read message comprises either control token 3, 32-bit of data, and control-token 1 (for success), or control tokens 4 and 1 (for failure).

A.3 Accessing node configuration

Node configuration registers can be accessed through the interconnect using the functions `write_node_config_reg(device, ...)` and `read_node_config_reg(device, ...)`, where `device` is the name of the node. These functions implement the protocols described below.

Instead of using the functions above, a channel-end can be allocated to communicate with the node configuration registers. The destination of the channel-end should be set to `0xnnnnC30c` where `nnnn` is the node-identifier.

A write message comprises the following:

control-token 192	24-bit response channel-end identifier	16-bit register number	32-bit data	control-token 1
----------------------	---	---------------------------	----------------	--------------------

The response to a write message comprises either control tokens 3 and 1 (for success), or control tokens 4 and 1 (for failure).

A read message comprises the following:

control-token 193	24-bit response channel-end identifier	16-bit register number	control-token 1
----------------------	---	---------------------------	--------------------

The response to a read message comprises either control token 3, 32-bit of data, and control-token 1 (for success), or control tokens 4 and 1 (for failure).

B Processor Status Configuration

The processor status control registers can be accessed directly by the processor using processor status reads and writes (use `getps(reg)` and `setps(reg,value)` for reads and writes).

The identifiers for the registers needs a prefix "XS1_PS_" and a postfix "_NUM", and are declared in "xs1.h"

Number	Perm	Description	Register identifier
0x00	RW	RAM base address	RAM_BASE
0x01	RW	Vector base address	VECTOR_BASE
0x02	RW	xCORE Tile control	XCORE_CTRL0
0x03	RO	xCORE Tile boot status	BOOT_CONFIG
0x05	RW	Security configuration	SECURITY_CONFIG
0x06	RW	Ring Oscillator Control	RING_OSC_CTRL
0x07	RO	Ring Oscillator Value	RING_OSC_DATA0
0x08	RO	Ring Oscillator Value	RING_OSC_DATA1
0x09	RO	Ring Oscillator Value	RING_OSC_DATA2
0x0A	RO	Ring Oscillator Value	RING_OSC_DATA3
0x0C	RO	RAM size	RAM_SIZE
0x10	DRW	Debug SSR	DBG_SSR
0x11	DRW	Debug SPC	DBG_SPC
0x12	DRW	Debug SSP	DBG_SSP
0x13	DRW	DGETREG operand 1	DBG_T_NUM
0x14	DRW	DGETREG operand 2	DBG_T_REG
0x15	DRW	Debug interrupt type	DBG_TYPE
0x16	DRW	Debug interrupt data	DBG_DATA
0x18	DRW	Debug core control	DBG_RUN_CTRL
0x20 .. 0x27	DRW	Debug scratch	DBG_SCRATCH
0x30 .. 0x33	DRW	Instruction breakpoint address	DBG_IBREAK_ADDR
0x40 .. 0x43	DRW	Instruction breakpoint control	DBG_IBREAK_CTRL
0x50 .. 0x53	DRW	Data watchpoint address 1	DBG_DWATCH_ADDR1
0x60 .. 0x63	DRW	Data watchpoint address 2	DBG_DWATCH_ADDR2
0x70 .. 0x73	DRW	Data breakpoint control register	DBG_DWATCH_CTRL

Figure 29:
Summary

Figure 30:
Summary
(continued)

Number	Perm	Description	Register identifier
0x80 .. 0x83	DRW	Resources breakpoint mask	DBG_RWATCH_ADDR1
0x90 .. 0x93	DRW	Resources breakpoint value	DBG_RWATCH_ADDR2
0x9C .. 0x9F	DRW	Resources breakpoint control register	DBG_RWATCH_CTRL

B.1 RAM base address

RAM_BASE 0x00

This register contains the base address of the RAM. It is initialized to 0x00040000.

0x00:
RAM base
address

Bits	Perm	Init	Description	Identifier
31:2	RW		Most significant 16 bits of all addresses.	WORD_ADDRESS_BITS
1:0	RO	-	Reserved	

B.2 Vector base address

VECTOR_BASE 0x01

Base address of event vectors in each resource. On an interrupt or event, the 16 most significant bits of the destination address are provided by this register; the least significant 16 bits come from the event vector.

0x01:
Vector base
address

Bits	Perm	Init	Description	Identifier
31:18	RW		The event and interrupt vectors.	VECTOR_BASE
17:0	RO	-	Reserved	

B.3 xCORE Tile control

XCORE_CTRL0 0x02

Register to control features in the xCORE tile

Bits	Perm	Init	Description	Identifier
31:26	RO	-	Reserved	
25:18	RW	0	RGMII TX data delay value (in PLL output cycle increments)	XCORE_CTRL0_RGMII_DELAY
17:9	RW	0	RGMII TX clock divider value. TX clk rises when counter (clocked by PLL output) reaches this value and falls when counter reaches (value»1). Value programmed into this field should be actual divide value required minus 1	XCORE_CTRL0_RGMII_DIVIDE
8	RW	0	Enable RGMII interface periph ports	XCORE_CTRL0_RGMII_ENABLE
7:6	RO	-	Reserved	
5	RW	0	Select the dynamic mode (1) for the clock divider when the clock divider is enabled. In dynamic mode the clock divider is only activated when all active threads are paused. In static mode the clock divider is always enabled.	XCORE_CTRL0_CLK_DIVIDER_DYN
4	RW	0	Enable the clock divider. This divides the output of the PLL to facilitate one of the low power modes.	XCORE_CTRL0_CLK_DIVIDER_EN
3:0	RO	-	Reserved	

0x02:
xCORE Tile
control

B.4 xCORE Tile boot status

BOOT_CONFIG 0x03

This read-only register describes the boot status of the xCORE tile.

Bits	Perm	Init	Description	Identifier
31:24	RO	-	Reserved	
23:16	RO		Processor number.	BOOT_CONFIG_PROCESSOR
15:9	RO	-	Reserved	
8	RO		Overwrite BOOT_MODE.	BOOT_CONFIG_SECURE_BOOT
7:6	RO	-	Reserved	
5	RO		Indicates if core1 has been powered off	BOOT_CONFIG_CORE1_POWER_DOWN_N
4	RO		Cause the ROM to not poll the OTP for correct read levels	BOOT_CONFIG_DISABLE_OTP_POLL
3	RO		Boot ROM boots from RAM	BOOT_CONFIG_BOOT_FROM_RAM
2	RO		Boot ROM boots from JTAG	BOOT_CONFIG_BOOT_FROM_JTAG
1:0	RO		The boot PLL mode pin value.	BOOT_CONFIG_PLL_MODE_PINS

0x03:
xCORE Tile
boot status

B.5 Security configuration

SECURITY_CONFIG 0x05

Copy of the security register as read from OTP.

Bits	Perm	Init	Description	Identifier
31	RW		Disables write permission on this register	SECUR_CFG_DISABLE_ACCESS
30:15	RO	-	Reserved	
14	RW		Disable access to XCore's global debug	SECUR_CFG_DISABLE_GLOBAL_DEBUG
13	RO	-	Reserved	
12	RW		lock all OTP sectors	SECUR_CFG_OTP_MASTER_LOCK
11:8	RW		lock bit for each OTP sector	SECUR_CFG_OTP_SECTOR_LOCK
7	RW		Enable OTP redundancy	SECUR_CFG_OTP_REDUNDANCY_ENABLE
6	RO	-	Reserved	
5	RW		Override boot mode and read boot image from OTP	SECUR_CFG_SECURE_BOOT
4	RW		Disable JTAG access to the PLL/BOOT configuration registers	SECUR_CFG_DISABLE_PLL_JTAG
3:1	RO	-	Reserved	
0	RW		Disable access to XCore's JTAG debug TAP	SECUR_CFG_DISABLE_XCORE_JTAG

0x05:
Security
configuration

B.6 Ring Oscillator Control

RING_OSC_CTRL 0x06

There are four free-running oscillators that clock four counters. The oscillators can be started and stopped using this register. The counters should only be read when the ring oscillator has been stopped for at least 10 core clock cycles (this can be achieved by inserting two nop instructions between the SETPS and GETPS). The counter values can be read using four subsequent registers. The ring oscillators are asynchronous to the xCORE tile clock and can be used as a source of random bits.

Bits	Perm	Init	Description	Identifier
31:2	RO	-	Reserved	
1	RW	0	Core ring oscillator enable.	RING_OSC_CORE_ENABLE
0	RW	0	Peripheral ring oscillator enable.	RING_OSC_PERPH_ENABLE

0x06:
Ring Oscillator
Control

B.7 Ring Oscillator Value

RING_OSC_DATA0 0x07

This register contains the current count of the xCORE Tile Cell ring oscillator. This value is not reset on a system reset.

Bits	Perm	Init	Description	Identifier
31:16	RO	-	Reserved	
15:0	RO	0	Ring oscillator Counter data.	RING_OSC_DATA

0x07:
Ring Oscillator
Value



B.8 Ring Oscillator Value

RING_OSC_DATA1 0x08

This register contains the current count of the xCORE Tile Wire ring oscillator. This value is not reset on a system reset.

0x08:
Ring Oscillator
Value

Bits	Perm	Init	Description	Identifier
31:16	RO	-	Reserved	
15:0	RO	0	Ring oscillator Counter data.	RING_OSC_DATA

B.9 Ring Oscillator Value

RING_OSC_DATA2 0x09

This register contains the current count of the Peripheral Cell ring oscillator. This value is not reset on a system reset.

0x09:
Ring Oscillator
Value

Bits	Perm	Init	Description	Identifier
31:16	RO	-	Reserved	
15:0	RO	0	Ring oscillator Counter data.	RING_OSC_DATA

B.10 Ring Oscillator Value

RING_OSC_DATA3 0x0A

This register contains the current count of the Peripheral Wire ring oscillator. This value is not reset on a system reset.

0x0A:
Ring Oscillator
Value

Bits	Perm	Init	Description	Identifier
31:16	RO	-	Reserved	
15:0	RO	0	Ring oscillator Counter data.	RING_OSC_DATA

B.11 RAM size

RAM_SIZE 0x0C

The size of the RAM in bytes

0x0C:
RAM size

Bits	Perm	Init	Description	Identifier
31:2	RO		Most significant 16 bits of all addresses.	WORD_ADDRESS_BITS
1:0	RO	-	Reserved	

B.12 Debug SSR

DBG_SSR 0x10

This register contains the value of the SSR register when the debugger was called.

Bits	Perm	Init	Description	Identifier
31:11	RO	-	Reserved	
10	DRW		Address space identifier	SR_QUEUE
9	DRW		Determines the issue mode (DI bit) upon Kernel Entry after Exception or Interrupt.	SR_KEDI
8	RO		Determines the issue mode (DI bit).	SR_DI
7	DRW		When 1 the thread is in fast mode and will continually issue.	SR_FAST
6	DRW		When 1 the thread is paused waiting for events, a lock or another resource.	SR_WAITING
5	RO	-	Reserved	
4	DRW		1 when in kernel mode.	SR_INK
3	DRW		1 when in an interrupt handler.	SR_ININT
2	DRW		1 when in an event enabling sequence.	SR_INENB
1	DRW		When 1 interrupts are enabled for the thread.	SR_IEBLE
0	DRW		When 1 events are enabled for the thread.	SR_EEBLE

0x10:
Debug SSR

B.13 Debug SPC

DBG_SPC 0x11

This register contains the value of the SPC register when the debugger was called.

0x11:
Debug SPC

Bits	Perm	Init	Description	Identifier
31:0	DRW		Value.	ALL_BITS

B.14 Debug SSP

DBG_SSP 0x12

This register contains the value of the SSP register when the debugger was called.

0x12:
Debug SSP

Bits	Perm	Init	Description	Identifier
31:0	DRW		Value.	ALL_BITS

B.15 DGETREG operand 1

DBG_T_NUM 0x13

The resource ID of the logical core whose state is to be read.

0x13:
DGETREG
operand 1

Bits	Perm	Init	Description	Identifier
31:8	RO	-	Reserved	
7:0	DRW		Thread number to be read	DBG_T_NUM_NUM

B.16 DGETREG operand 2

DBG_T_REG 0x14

Register number to be read by DGETREG

0x14:
DGETREG
operand 2

Bits	Perm	Init	Description	Identifier
31:5	RO	-	Reserved	
4:0	DRW		Register number to be read	DBG_T_REG_REG

B.17 Debug interrupt type

DBG_TYPE 0x15

Register that specifies what activated the debug interrupt.

0x15:
Debug
interrupt type

Bits	Perm	Init	Description	Identifier
31:18	RO	-	Reserved	
17:16	DRW		Number of the hardware breakpoint/watchpoint which caused the interrupt (always 0 for =HOST= and =DCALL=). If multiple breakpoints/watchpoints trigger at once, the lowest number is taken.	DBG_TYPE_HW_NUM
15:8	DRW		Number of thread which caused the debug interrupt (always 0 in the case of =HOST=).	DBG_TYPE_T_NUM
7:3	RO	-	Reserved	
2:0	DRW	0	Indicates the cause of the debug interrupt 1: Host initiated a debug interrupt through JTAG 2: Program executed a DCALL instruction 3: Instruction breakpoint 4: Data watch point 5: Resource watch point	DBG_TYPE_CAUSE

B.18 Debug interrupt data

DBG_DATA 0x16

On a data watchpoint, this register contains the effective address of the memory operation that triggered the debugger. On a resource watchpoint, it contains the resource identifier.

0x16:
Debug
interrupt data

Bits	Perm	Init	Description	Identifier
31:0	DRW		Value.	ALL_BITS

B.19 Debug core control

DBG_RUN_CTRL 0x18

This register enables the debugger to temporarily disable logical cores. When returning from the debug interrupts, the cores set in this register will not execute. This enables single stepping to be implemented.

0x18:
Debug core
control

Bits	Perm	Init	Description	Identifier
31:8	RO	-	Reserved	
7:0	DRW		1-hot vector defining which threads are stopped when not in debug mode. Every bit which is set prevents the respective thread from running.	DBG_RUN_CTRL_STOP

B.20 Debug scratch

DBG_SCRATCH 0x20 .. 0x27

A set of registers used by the debug ROM to communicate with an external debugger, for example over JTAG. This is the same set of registers as the [Debug Scratch registers in the xCORE tile configuration](#).

0x20 .. 0x27:
Debug scratch

Bits	Perm	Init	Description	Identifier
31:0	DRW		Value.	ALL_BITS

B.21 Instruction breakpoint address

DBG_IBREAK_ADDR 0x30 .. 0x33

This register contains the address of the instruction breakpoint. If the PC matches this address, then a debug interrupt will be taken. There are four instruction breakpoints that are controlled individually.

0x30 .. 0x33:
Instruction
breakpoint
address

Bits	Perm	Init	Description	Identifier
31:0	DRW		Value.	ALL_BITS

B.22 Instruction breakpoint control

DBG_IBREAK_CTRL 0x40 .. 0x43

This register controls which logical cores may take an instruction breakpoint, and under which condition.

0x40 .. 0x43:
Instruction
breakpoint
control

Bits	Perm	Init	Description	Identifier
31:24	RO	-	Reserved	
23:16	DRW	0	A bit for each thread in the machine allowing the breakpoint to be enabled individually for each thread.	BRK_THREADS
15:2	RO	-	Reserved	
1	DRW	0	When 0 break when PC == IBREAK_ADDR. When 1 = break when PC != IBREAK_ADDR.	IBRK_CONDITION
0	DRW	0	When 1 the instruction breakpoint is enabled.	BRK_ENABLE

B.23 Data watchpoint address 1 DBG_DWATCH_ADDR1 0x50 .. 0x53

This set of registers contains the first address for the four data watchpoints.

0x50 .. 0x53:

Data
watchpoint
address 1

Bits	Perm	Init	Description	Identifier
31:0	DRW		Value.	ALL_BITS

B.24 Data watchpoint address 2 DBG_DWATCH_ADDR2 0x60 .. 0x63

This set of registers contains the second address for the four data watchpoints.

0x60 .. 0x63:

Data
watchpoint
address 2

Bits	Perm	Init	Description	Identifier
31:0	DRW		Value.	ALL_BITS

B.25 Data breakpoint control register DBG_DWATCH_CTRL 0x70 .. 0x73

This set of registers controls each of the four data watchpoints.

0x70 .. 0x73:

Data
breakpoint
control
register

Bits	Perm	Init	Description	Identifier
31:24	RO	-	Reserved	
23:16	DRW	0	A bit for each thread in the machine allowing the breakpoint to be enabled individually for each thread.	BRK_THREADS
15:3	RO	-	Reserved	
2	DRW	0	When 1 the breakpoints will be triggered on loads.	BRK_LOAD
1	DRW	0	Determines the break condition: 0 = A AND B, 1 = A OR B.	DBRK_CONDITION
0	DRW	0	When 1 the instruction breakpoint is enabled.	BRK_ENABLE

B.26 Resources breakpoint mask DBG_RWATCH_ADDR1 0x80 .. 0x83

This set of registers contains the mask for the four resource watchpoints.

0x80 .. 0x83:

Resources
breakpoint
mask

Bits	Perm	Init	Description	Identifier
31:0	DRW		Value.	ALL_BITS



B.27 Resources breakpoint value DBG_RWATCH_ADDR2 0x90 .. 0x93

This set of registers contains the value for the four resource watchpoints.

0x90 .. 0x93:
Resources
breakpoint
value

Bits	Perm	Init	Description	Identifier
31:0	DRW		Value.	ALL_BITS

B.28 Resources breakpoint control register DBG_RWATCH_CTRL 0x9C .. 0x9F

This set of registers controls each of the four resource watchpoints.

0x9C .. 0x9F:
Resources
breakpoint
control
register

Bits	Perm	Init	Description	Identifier
31:24	RO	-	Reserved	
23:16	DRW	0	A bit for each thread in the machine allowing the breakpoint to be enabled individually for each thread.	BRK_THREADS
15:2	RO	-	Reserved	
1	DRW	0	When 0 break when condition A is met. When 1 = break when condition B is met.	BRK_CONDITION
0	DRW	0	When 1 the instruction breakpoint is enabled.	BRK_ENABLE

C Tile Configuration

The xCORE Tile control registers can be accessed using configuration reads and writes (use `write_tile_config_reg(tileref, ...)` and `read_tile_config_reg(tileref, ...)` for reads and writes).

The identifiers for the registers needs a prefix "XS1_PSWITCH_" and a postfix "_NUM", and are declared in "xs1.h"

Number	Perm	Description	Register identifier
0x00	CRO	Device identification	DEVICE_ID0
0x01	CRO	xCORE Tile description 1	DEVICE_ID1
0x02	CRO	xCORE Tile description 2	DEVICE_ID2
0x04	CRW	Control PSwitch permissions to debug registers	DBG_CTRL
0x05	CRW	Cause debug interrupts	DBG_INT
0x06	CRW	xCORE Tile clock divider	PLL_CLK_DIVIDER
0x07	CRO	Security configuration	SECU_CONFIG
0x20 .. 0x27	CRW	Debug scratch	DBG_SCRATCH
0x40	CRO	PC of logical core 0	T0_PC
0x41	CRO	PC of logical core 1	T1_PC
0x42	CRO	PC of logical core 2	T2_PC
0x43	CRO	PC of logical core 3	T3_PC
0x44	CRO	PC of logical core 4	T4_PC
0x45	CRO	PC of logical core 5	T5_PC
0x46	CRO	PC of logical core 6	T6_PC
0x47	CRO	PC of logical core 7	T7_PC
0x60	CRO	SR of logical core 0	T0_SR
0x61	CRO	SR of logical core 1	T1_SR
0x62	CRO	SR of logical core 2	T2_SR
0x63	CRO	SR of logical core 3	T3_SR
0x64	CRO	SR of logical core 4	T4_SR
0x65	CRO	SR of logical core 5	T5_SR
0x66	CRO	SR of logical core 6	T6_SR
0x67	CRO	SR of logical core 7	T7_SR

Figure 31:
Summary

C.1 Device identification

DEVICE_ID0 0x00

This register identifies the xCORE Tile

0x00:
Device
identification

Bits	Perm	Init	Description	Identifier
31:24	CRO		Processor ID of this XCore.	DEVICE_ID0_PID
23:16	CRO		Number of the node in which this XCore is located.	DEVICE_ID0_NODE
15:8	CRO		XCore revision.	DEVICE_ID0_REVISION
7:0	CRO		XCore version.	DEVICE_ID0_VERSION

C.2 xCORE Tile description 1

DEVICE_ID1 0x01

This register describes the number of logical cores, synchronisers, locks and channel ends available on this xCORE tile.

0x01:
xCORE Tile
description 1

Bits	Perm	Init	Description	Identifier
31:24	CRO		Number of channel ends.	DEVICE_ID1_NUM_CHANENDS
23:16	CRO		Number of the locks.	DEVICE_ID1_NUM_LOCKS
15:8	CRO		Number of synchronisers.	DEVICE_ID1_NUM_SYNCs
7:0	RO	-	Reserved	

C.3 xCORE Tile description 2

DEVICE_ID2 0x02

This register describes the number of timers and clock blocks available on this xCORE tile.

0x02:
xCORE Tile
description 2

Bits	Perm	Init	Description	Identifier
31:16	RO	-	Reserved	
15:8	CRO		Number of clock blocks.	DEVICE_ID2_NUM_CLKBLKS
7:0	CRO		Number of timers.	DEVICE_ID2_NUM_TIMERS

C.4 Control PSwitch permissions to debug registers

DBG_CTRL 0x04

This register can be used to control whether the debug registers (marked with permission CRW) are accessible through the tile configuration registers. When this bit is set, write-access to those registers is disabled, preventing debugging of the xCORE tile over the interconnect.

0x04:
Control
PSwitch
permissions
to debug
registers

Bits	Perm	Init	Description	Identifier
31	CRW	0	When 1 the PSwitch is restricted to RO access to all CRW registers from SSwitch, XCore(PS_DBG_Scratch) and JTAG	DBG_CTRL_PSWITCH_RO
30:1	RO	-	Reserved	
0	CRW	0	When 1 the PSwitch is restricted to RO access to all CRW registers from SSwitch	DBG_CTRL_PSWITCH_RO_EXT

C.5 Cause debug interrupts

DBG_INT 0x05

This register can be used to raise a debug interrupt in this xCORE tile.

0x05:
Cause debug
interrupts

Bits	Perm	Init	Description	Identifier
31:2	RO	-	Reserved	
1	CRW	0	1 when the processor is in debug mode.	DBG_INT_IN_DBG
0	CRW	0	Request a debug interrupt on the processor.	DBG_INT_REQ_DBG

C.6 xCORE Tile clock divider

PLL_CLK_DIVIDER 0x06

This register contains the value used to divide the PLL clock to create the xCORE tile clock. The divider is enabled under control of the [tile control register](#)

0x06:
xCORE Tile
clock divider

Bits	Perm	Init	Description	Identifier
31	CRW	0	Clock disable. Writing '1' will remove the clock to the tile.	PLL_CLK_DISABLE
30:16	RO	-	Reserved	
15:0	CRW	0	Clock divider.	PLL_CLK_DIVIDER

C.7 Security configuration

SECU_CONFIG 0x07

Copy of the security register as read from OTP.

Bits	Perm	Init	Description	Identifier
31	CRO		Disables write permission on this register	SECUR_CFG_DISABLE_ACCESS
30:15	RO	-	Reserved	
14	CRO		Disable access to XCore's global debug	SECUR_CFG_DISABLE_GLOBAL_DEBUG
13	RO	-	Reserved	
12	CRO		lock all OTP sectors	SECUR_CFG_OTP_MASTER_LOCK
11:8	CRO		lock bit for each OTP sector	SECUR_CFG_OTP_SECTOR_LOCK
7	CRO		Enable OTP redundancy	SECUR_CFG_OTP_REDUNDANCY_ENABLE
6	RO	-	Reserved	
5	CRO		Override boot mode and read boot image from OTP	SECUR_CFG_SECURE_BOOT
4	CRO		Disable JTAG access to the PLL/BOOT configuration registers	SECUR_CFG_DISABLE_PLL_JTAG
3:1	RO	-	Reserved	
0	CRO		Disable access to XCore's JTAG debug TAP	SECUR_CFG_DISABLE_XCORE_JTAG

0x07:
Security
configuration

C.8 Debug scratch

DBG_SCRATCH 0x20 .. 0x27

A set of registers used by the debug ROM to communicate with an external debugger, for example over the switch. This is the same set of registers as the [Debug Scratch registers in the processor status](#).

0x20 .. 0x27:
Debug scratch

Bits	Perm	Init	Description	Identifier
31:0	CRW		Value.	ALL_BITS

C.9 PC of logical core 0

T0_PC 0x40

Value of the PC of logical core 0.

0x40:
PC of logical
core 0

Bits	Perm	Init	Description	Identifier
31:0	CRO		Value.	ALL_BITS

C.10 PC of logical core 1

T1_PC 0x41

Value of the PC of logical core 1.

0x41:
PC of logical core 1

Bits	Perm	Init	Description	Identifier
31:0	CRO		Value.	ALL_BITS

C.11 PC of logical core 2 T2_PC 0x42

Value of the PC of logical core 2.

0x42:
PC of logical core 2

Bits	Perm	Init	Description	Identifier
31:0	CRO		Value.	ALL_BITS

C.12 PC of logical core 3 T3_PC 0x43

Value of the PC of logical core 3.

0x43:
PC of logical core 3

Bits	Perm	Init	Description	Identifier
31:0	CRO		Value.	ALL_BITS

C.13 PC of logical core 4 T4_PC 0x44

Value of the PC of logical core 4.

0x44:
PC of logical core 4

Bits	Perm	Init	Description	Identifier
31:0	CRO		Value.	ALL_BITS

C.14 PC of logical core 5 T5_PC 0x45

Value of the PC of logical core 5.

0x45:
PC of logical core 5

Bits	Perm	Init	Description	Identifier
31:0	CRO		Value.	ALL_BITS

C.15 PC of logical core 6 T6_PC 0x46

Value of the PC of logical core 6.



0x46:
PC of logical
core 6

Bits	Perm	Init	Description	Identifier
31:0	CRO		Value.	ALL_BITS

C.16 PC of logical core 7

T7_PC 0x47

Value of the PC of logical core 7.

0x47:
PC of logical
core 7

Bits	Perm	Init	Description	Identifier
31:0	CRO		Value.	ALL_BITS

C.17 SR of logical core 0

T0_SR 0x60

Value of the SR of logical core 0

0x60:
SR of logical
core 0

Bits	Perm	Init	Description	Identifier
31:0	CRO		Value.	ALL_BITS

C.18 SR of logical core 1

T1_SR 0x61

Value of the SR of logical core 1

0x61:
SR of logical
core 1

Bits	Perm	Init	Description	Identifier
31:0	CRO		Value.	ALL_BITS

C.19 SR of logical core 2

T2_SR 0x62

Value of the SR of logical core 2

0x62:
SR of logical
core 2

Bits	Perm	Init	Description	Identifier
31:0	CRO		Value.	ALL_BITS

C.20 SR of logical core 3

T3_SR 0x63

Value of the SR of logical core 3

0x63:
SR of logical
core 3

Bits	Perm	Init	Description	Identifier
31:0	CRO		Value.	ALL_BITS

C.21 SR of logical core 4

T4_SR 0x64

Value of the SR of logical core 4

0x64:
SR of logical
core 4

Bits	Perm	Init	Description	Identifier
31:0	CRO		Value.	ALL_BITS

C.22 SR of logical core 5

T5_SR 0x65

Value of the SR of logical core 5

0x65:
SR of logical
core 5

Bits	Perm	Init	Description	Identifier
31:0	CRO		Value.	ALL_BITS

C.23 SR of logical core 6

T6_SR 0x66

Value of the SR of logical core 6

0x66:
SR of logical
core 6

Bits	Perm	Init	Description	Identifier
31:0	CRO		Value.	ALL_BITS

C.24 SR of logical core 7

T7_SR 0x67

Value of the SR of logical core 7

0x67:
SR of logical
core 7

Bits	Perm	Init	Description	Identifier
31:0	CRO		Value.	ALL_BITS

D Node Configuration

The digital node control registers can be accessed using configuration reads and writes (use `write_node_config_reg(device, ...)` and `read_node_config_reg(device, ...)` for reads and writes).

The identifiers for the registers needs a prefix “XS1_SSWITCH_” and a postfix “_NUM”, and are declared in “xs1.h”

Number	Perm	Description	Register identifier
0x00	RO	Device identification	DEVICE_ID0
0x01	RO	System switch description	DEVICE_ID1
0x04	RW	Switch configuration	NODE_CONFIG
0x05	RW	Switch node identifier	NODE_ID
0x06	RW	PLL settings	PLL_CTL
0x07	RW	System switch clock divider	CLK_DIVIDER
0x08	RW	Reference clock	REF_CLK_DIVIDER
0x09	R	System JTAG device ID register	JTAG_DEVICE_ID
0x0A	R	System USERCODE register	JTAG_USERCODE
0x0C	RW	Directions 0-7	DIMENSION_DIRECTION0
0x0D	RW	Directions 8-15	DIMENSION_DIRECTION1
0x10	RW	DEBUG_N configuration, tile 0	XCORE0_GLOBAL_DEBUG_CONFIG
0x11	RW	DEBUG_N configuration, tile 1	XCORE1_GLOBAL_DEBUG_CONFIG
0x1F	RO	Debug source	GLOBAL_DEBUG_SOURCE
0x20 .. 0x28	RW	Link status, direction, and network	SLINK
0x40 .. 0x47	RO	PLink status and network	PLINK
0x80 .. 0x88	RW	Link configuration and initialization	XLINK
0xA0 .. 0xA7	RW	Static link configuration	XSTATIC

Figure 32:
Summary

D.1 Device identification

DEVICE_ID0 0x00

This register contains version and revision identifiers and the mode-pins as sampled at boot-time.

Bits	Perm	Init	Description	Identifier
31:24	RO	-	Reserved	
23:16	RO		Sampled values of BootCtl pins on Power On Reset.	SS_DEVICE_ID0_BOOT_CTRL
15:8	RO		SSwitch revision.	SS_DEVICE_ID0_REVISION
7:0	RO		SSwitch version.	SS_DEVICE_ID0_VERSION

0x00:
Device
identification

D.2 System switch description

DEVICE_ID1 0x01

This register specifies the number of processors and links that are connected to this switch.

0x01:
System switch
description

Bits	Perm	Init	Description	Identifier
31:24	RO	-	Reserved	
23:16	RO		Number of SLinks on the SSwitch.	SS_DEVICE_ID1_NUM_SLINKS
15:8	RO		Number of processors on the SSwitch.	SS_DEVICE_ID1_NUM_PROCESSORS
7:0	RO		Number of processors on the device.	SS_DEVICE_ID1_NUM_PLINKS_PER_PROC

D.3 Switch configuration

NODE_CONFIG 0x04

This register enables the setting of two security modes (that disable updates to the PLL or any other registers) and the header-mode.

0x04:
Switch
configuration

Bits	Perm	Init	Description	Identifier
31	RW	0	0 = SSCTL registers have write access. 1 = SSCTL registers can not be written to.	SS_NODE_CONFIG_DISABLE_SSCTL_UPDATE
30:9	RO	-	Reserved	
8	RW	0	0 = PLL_CTL_REG has write access. 1 = PLL_CTL_REG can not be written to.	SS_NODE_CONFIG_DISABLE_PLL_CTL_REG
7:1	RO	-	Reserved	
0	RW	0	0 = 2-byte headers, 1 = 1-byte headers (reset as 0).	SS_NODE_CONFIG_HEADERS

D.4 Switch node identifier

NODE_ID 0x05

This register contains the node identifier.

0x05:
Switch node
identifier

Bits	Perm	Init	Description	Identifier
31:16	RO	-	Reserved	
15:0	RW	0	The unique ID of this node.	SS_NODE_ID_ID

D.5 PLL settings

PLL_CTL 0x06

An on-chip PLL multiplies the input clock up to a higher frequency clock, used to clock the I/O, processor, and switch, see [Oscillator](#). Note: a write to this register will cause the tile to be reset.



Bits	Perm	Init	Description	Identifier
31	RW		If set to 1, the chip will not be reset	SS_PLL_CTL_MRESET
30	RW		If set to 1, the chip will not wait for the PLL to re-lock. Only use this if a gradual change is made to the PLL	SS_PLL_CTL_MLOCK
29	DW		If set to 1, set the PLL to be bypassed	SS_TEST_MODE_PLL_BYPASS
28	DW		If set to 1, set the boot mode to boot from JTAG	SS_TEST_MODE_BOOT_JTAG
27:26	RO	-	Reserved	
25:23	RW		Output divider value range from 0 (8'h0) to 7 (8'h7). OD value.	SS_PLL_CTL_POST_DIVISOR
22:21	RO	-	Reserved	
20:8	RW		Feedback multiplication ratio, range from 0 (8'h0) to 4095 (8'h3FF). F value.	SS_PLL_CTL_FEEDBACK_MUL
7	RO	-	Reserved	
6:0	RW		Oscillator input divider value range from 0 (8'h0) to 63 (8'h3F). R value.	SS_PLL_CTL_INPUT_DIVISOR

0x06:
PLL settings

D.6 System switch clock divider

CLK_DIVIDER 0x07

Sets the ratio of the PLL clock and the switch clock.

Bits	Perm	Init	Description	Identifier
31:16	RO	-	Reserved	
15:0	RW	0	SSwitch clock generation	SS_CLK_DIVIDER_CLK_DIV

0x07:
System switch
clock divider

D.7 Reference clock

REF_CLK_DIVIDER 0x08

Sets the ratio of the PLL clock and the reference clock used by the node.

Bits	Perm	Init	Description	Identifier
31:16	RO	-	Reserved	
15:0	RW	3	Software ref. clock divider	SS_SSWITCH_REF_CLK_DIV

0x08:
Reference
clock

D.8 System JTAG device ID register

JTAG_DEVICE_ID 0x09

0x09:
System JTAG
device ID
register

Bits	Perm	Init	Description	Identifier
31:28	RO			SS_JTAG_DEVICE_ID_VERSION
27:12	RO			SS_JTAG_DEVICE_ID_PART_NUM
11:1	RO			SS_JTAG_DEVICE_ID_MANU_ID
0	RO			SS_JTAG_DEVICE_ID_CONST_VAL

D.9 System USERCODE register

JTAG_USERCODE 0x0A

0x0A:
System
USERCODE
register

Bits	Perm	Init	Description	Identifier
31:18	RO		JTAG USERCODE value programmed into OTP SR	SS_JTAG_USERCODE_OTP
17:0	RO		metal fixable ID code	SS_JTAG_USERCODE_MASK_ID

D.10 Directions 0-7

DIMENSION_DIRECTION0 0x0C

This register contains eight directions, for packets with a mismatch in bits 7..0 of the node-identifier. The direction in which a packet will be routed is governed by the most significant mismatching bit.

0x0C:
Directions 0-7

Bits	Perm	Init	Description	Identifier
31:28	RW	0	The direction for packets whose dimension is 7.	DIM7_DIR
27:24	RW	0	The direction for packets whose dimension is 6.	DIM6_DIR
23:20	RW	0	The direction for packets whose dimension is 5.	DIM5_DIR
19:16	RW	0	The direction for packets whose dimension is 4.	DIM4_DIR
15:12	RW	0	The direction for packets whose dimension is 3.	DIM3_DIR
11:8	RW	0	The direction for packets whose dimension is 2.	DIM2_DIR
7:4	RW	0	The direction for packets whose dimension is 1.	DIM1_DIR
3:0	RW	0	The direction for packets whose dimension is 0.	DIM0_DIR

D.11 Directions 8-15

DIMENSION_DIRECTION1 0x0D

This register contains eight directions, for packets with a mismatch in bits 15..8 of the node-identifier. The direction in which a packet will be routed is governed by the most significant mismatching bit.



0x0D:
Directions
8-15

Bits	Perm	Init	Description	Identifier
31:28	RW	0	The direction for packets whose dimension is F.	DIMF_DIR
27:24	RW	0	The direction for packets whose dimension is E.	DIME_DIR
23:20	RW	0	The direction for packets whose dimension is D.	DIMD_DIR
19:16	RW	0	The direction for packets whose dimension is C.	DIMC_DIR
15:12	RW	0	The direction for packets whose dimension is B.	DIMB_DIR
11:8	RW	0	The direction for packets whose dimension is A.	DIMA_DIR
7:4	RW	0	The direction for packets whose dimension is 9.	DIM9_DIR
3:0	RW	0	The direction for packets whose dimension is 8.	DIM8_DIR

D.12 DEBUG_N configuration, tile 0 XCORE0_GLOBAL_DEBUG_CONFIG 0x10

Configures the behavior of the DEBUG_N pin.

0x10:
DEBUG_N
configuration,
tile 0

Bits	Perm	Init	Description	Identifier
31:2	RO	-	Reserved	
1	RW	0	Set 1 to enable GlobalDebug to generate debug request to XCore.	GLOBAL_DEBUG_ENABLE_GLOBAL_DEBUG_REQ
0	RW	0	Set 1 to enable inDebug bit to drive GlobalDebug.	GLOBAL_DEBUG_ENABLE_INDEBUG

D.13 DEBUG_N configuration, tile 1 XCORE1_GLOBAL_DEBUG_CONFIG 0x11

Configures the behavior of the DEBUG_N pin.

0x11:
DEBUG_N
configuration,
tile 1

Bits	Perm	Init	Description	Identifier
31:2	RO	-	Reserved	
1	RW	0	Set 1 to enable GlobalDebug to generate debug request to XCore.	GLOBAL_DEBUG_ENABLE_GLOBAL_DEBUG_REQ
0	RW	0	Set 1 to enable inDebug bit to drive GlobalDebug.	GLOBAL_DEBUG_ENABLE_INDEBUG

D.14 Debug source GLOBAL_DEBUG_SOURCE 0x1F

Contains the source of the most recent debug event.

Bits	Perm	Init	Description	Identifier
31:5	RO	-	Reserved	
4	RW		If set, external pin, is the source of last GlobalDebug event.	GLOBAL_DEBUG_SOURCE_EXTERNAL_PAD_INDEBUG
3:2	RO	-	Reserved	
1	RW		If set, XCore1 is the source of last GlobalDebug event.	GLOBAL_DEBUG_SOURCE_XCORE1_INDEBUG
0	RW		If set, XCore0 is the source of last GlobalDebug event.	GLOBAL_DEBUG_SOURCE_XCORE0_INDEBUG

0x1F:
Debug source

D.15 Link status, direction, and network

SLINK 0x20 .. 0x28

These registers contain status information for low level debugging (read-only), the network number that each link belongs to, and the direction that each link is part of. The registers control links 0..7.

Bits	Perm	Init	Description	Identifier
31:26	RO	-	Reserved	
25:24	RO		Identify the SRC_TARGET type 0 - SLink, 1 - PLink, 2 - SSCTL, 3 - Undefine.	SLINK_SRC_TARGET_TYPE
23:16	RO		When the link is in use, this is the destination link number to which all packets are sent.	SLINK_SRC_TARGET_ID
15:12	RO	-	Reserved	
11:8	RW	0	The direction that this link operates in.	LINK_DIRECTION
7:6	RO	-	Reserved	
5:4	RW	0	Determines the network to which this link belongs, reset as 0.	LINK_NETWORK
3	RO	-	Reserved	
2	RO		1 when the current packet is considered junk and will be thrown away.	LINK_JUNK
1	RO		1 when the dest side of the link is in use.	LINK_DST_INUSE
0	RO		1 when the source side of the link is in use.	LINK_SRC_INUSE

0x20 .. 0x28:
Link status,
direction, and
network

D.16 PLink status and network

PLINK 0x40 .. 0x47

These registers contain status information and the network number that each processor-link belongs to.

Bits	Perm	Init	Description	Identifier
31:26	RO	-	Reserved	
25:24	RO		Identify the SRC_TARGET type 0 - SLink, 1 - PLink, 2 - SSCTL, 3 - Undefined.	PLINK_SRC_TARGET_TYPE
23:16	RO		When the link is in use, this is the destination link number to which all packets are sent.	PLINK_SRC_TARGET_ID
15:6	RO	-	Reserved	
5:4	RW	0	Determines the network to which this link belongs, reset as 0.	LINK_NETWORK
3	RO	-	Reserved	
2	RO		1 when the current packet is considered junk and will be thrown away.	LINK_JUNK
1	RO		1 when the dest side of the link is in use.	LINK_DST_INUSE
0	RO		1 when the source side of the link is in use.	LINK_SRC_INUSE

0x40 .. 0x47:
PLink status
and network

D.17 Link configuration and initialization

XLINK 0x80 .. 0x88

These registers contain configuration and debugging information specific to external links. The link speed and width can be set, the link can be initialized, and the link status can be monitored. The registers control links 0..7.

Bits	Perm	Init	Description	Identifier
31	RW		Write to this bit with '1' will enable the XLink, writing '0' will disable it. This bit controls the muxing of ports with overlapping xlinks.	XLINK_ENABLE
30	RW	0	0: operate in 2 wire mode; 1: operate in 5 wire mode	XLINK_WIDE
29:28	RO	-	Reserved	
27	RO		Rx buffer overflow or illegal token encoding received.	XLINK_RX_ERROR
26	RO	0	This end of the xlink has issued credit to allow the remote end to transmit	RX_CREDIT
25	RO	0	This end of the xlink has credit to allow it to transmit.	TX_CREDIT
24	WO		Clear this end of the xlink's credit and issue a HELLO token.	XLINK_HELLO
23	WO		Reset the receiver. The next symbol that is detected will be the first symbol in a token.	XLINK_RX_RESET
22	RO	-	Reserved	
21:11	RW	0	Specify min. number of idle system clocks between two continuous symbols within a transmit token -1.	XLINK_INTRA_TOKEN_DELAY
10:0	RW	0	Specify min. number of idle system clocks between two continuous transmit tokens -1.	XLINK_INTER_TOKEN_DELAY

0x80 .. 0x88:
Link
configuration
and
initialization



D.18 Static link configuration

XSTATIC 0xA0 .. 0xA7

These registers are used for static (ie, non-routed) links. When a link is made static, all traffic is forwarded to the designated channel end and no routing is attempted. The registers control links C, D, A, B, G, H, E, and F in that order.

0xA0 .. 0xA7:
Static link configuration

Bits	Perm	Init	Description	Identifier
31	RW	0	Enable static forwarding.	XSTATIC_ENABLE
30:9	RO	-	Reserved	
8	RW	0	The destination processor on this node that packets received in static mode are forwarded to.	XSTATIC_DEST_PROC
7:5	RO	-	Reserved	
4:0	RW	0	The destination channel end on this node that packets received in static mode are forwarded to.	XSTATIC_DEST_CHAN_END



E JTAG, xSCOPE and Debugging

If you intend to design a board that can be used with the XMOS toolchain and xTAG debugger, you will need an xSYS header on your board. Figure 33 shows a decision diagram which explains what type of xSYS connectivity you need. The three subsections below explain the options in detail.

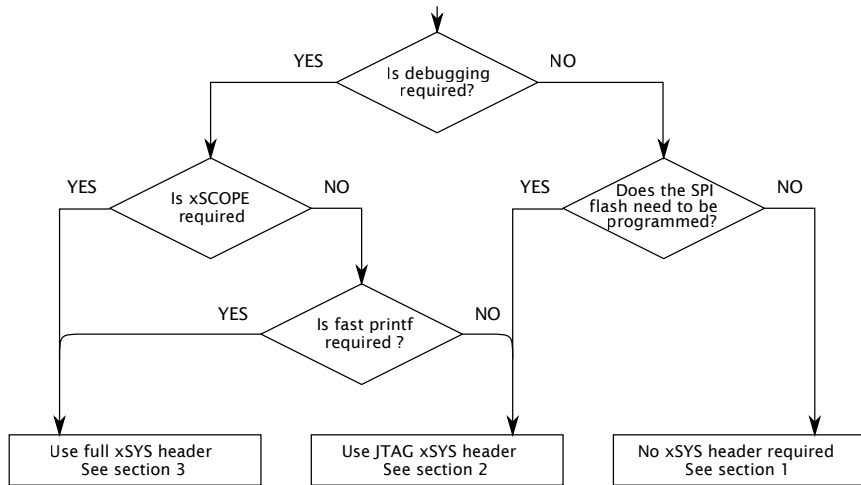

Figure 33:

Decision diagram for the xSYS header

E.1 No xSYS header

The use of an xSYS header is optional, and may not be required for volume production designs. However, the XMOS toolchain expects the xSYS header; if you do not have an xSYS header then you must provide your own method for writing to flash/OTP and for debugging.

E.2 JTAG-only xSYS header

The xSYS header connects to an xTAG debugger, which has a 20-pin 0.1" female IDC header. The design will hence need a male IDC header. We advise to use a boxed header to guard against incorrect plug-ins. If you use a 90 degree angled header, make sure that pins 2, 4, 6, ..., 20 are along the edge of the PCB.

Connect pins 4, 8, 12, 16, 20 of the xSYS header to ground, and then connect:

- ▶ TDI to pin 5 of the xSYS header
- ▶ TMS to pin 7 of the xSYS header
- ▶ TCK to pin 9 of the xSYS header
- ▶ DEBUG_N to pin 11 of the xSYS header
- ▶ TDO to pin 13 of the xSYS header

The RST_N net should be open-drain, active-low, and have a pull-up to VDDIO.

E.3 Full xSYS header

For a full xSYS header you will need to connect the pins as discussed in Section E.2, and then connect a 2-wire xCONNECT Link to the xSYS header. The links can be found in the Signal description table (Section 4): they are labelled XL0, XL1, etc in the function column. The 2-wire link comprises two inputs and outputs, labelled ${}^1_{out}$, ${}^0_{out}$, ${}^0_{in}$, and ${}^1_{in}$. For example, if you choose to use XL0 for xSCOPE I/O, you need to connect up $XL0^1_{out}$, $XL0^0_{out}$, $XL0^0_{in}$, $XL0^1_{in}$ as follows:

- ▶ $XL0^1_{out}$ (X0D43) to pin 6 of the xSYS header with a 33R series resistor close to the device.
- ▶ $XL0^0_{out}$ (X0D42) to pin 10 of the xSYS header with a 33R series resistor close to the device.
- ▶ $XL0^0_{in}$ (X0D41) to pin 14 of the xSYS header.
- ▶ $XL0^1_{in}$ (X0D40) to pin 18 of the xSYS header.

F Schematics Design Check List

- This section is a checklist for use by schematics designers using the XLF224-512-FB374. Each of the following sections contains items to check for each design.

F.1 Power supplies

- The VDD (core) supply ramps monotonically (rises constantly) from 0V to its final value (0.95V - 1.05V) within 10ms (Section 11).
- The VDD (core) supply is capable of supplying 1400 mA (Section 11 and Figure 17).
- PLL_AVDD is filtered with a low pass filter, for example an RC filter, see Section 11

F.2 Power supply decoupling

- The design has multiple decoupling capacitors per supply, for example at least four 0402 or 0603 size surface mount capacitors of 100nF in value, per supply (Section 11).
- A bulk decoupling capacitor of at least 10uF is placed on each supply (Section 11).

F.3 Power on reset

- The RST_N and TRST_N pins are asserted (low) until all supplies are good. There is enough time between VDDIO power good and RST_N to allow any boot flash to settle.

F.4 Clock

- The CLK input pin is supplied with a clock with monotonic rising edges and low jitter.
- Pins MODE0 and MODE1 are set to the correct value for the chosen oscillator frequency. The MODE settings are shown in the Oscillator section, Section 7. If you have a choice between two values, choose the value with the highest multiplier ratio since that will boot faster.

F.5 Boot

- X0D01 has a 1K pull-up to VDDIO (Section 8).

- The device is kept in reset for at least 1 ms after VDDIO has reached its minimum level (Section 8).

F.6 JTAG, XScope, and debugging

- You have decided as to whether you need an XSYS header or not (Section E)
- If you have not included an XSYS header, you have devised a method to program the SPI-flash or OTP (Section E).

F.7 GPIO

- You have not mapped both inputs and outputs to the same multi-bit port.
- Pins X0D04, X0D05, X0D06, and X0D07 are output only and are, during and after reset, pulled low or not connected (Section 8)
- Pins X2D04, X2D05, X2D06 and X2D07 are output only and during and after reset, X2D06 is pulled high and X2D04, X2D05, and X2D07 are pulled low (Section 8)

F.8 Multi device designs

Skip this section if your design only includes a single XMOS device.

- One device is connected to a QSPI or SPI flash for booting.
- Devices that boot from link have, for example, X0D06 pulled high and have link XL0 connected to a device to boot from (Section 8).

G PCB Layout Design Check List

- This section is a checklist for use by PCB designers using the XS2-LF24B-512-FB374. Each of the following sections contains items to check for each design.

G.1 Ground Plane

- Each ground ball has a via to minimize impedance and conduct heat away from the device. (Section 11.2)
- Other than ground vias, there are no (or only a few) vias underneath or closely around the device. This create a good, solid, ground plane.

G.2 Power supply decoupling

- The decoupling capacitors are all placed close to a supply pin (Section 11).
- The decoupling capacitors are spaced around the device (Section 11).
- The ground side of each decoupling capacitor has a direct path back to the center ground of the device.

G.3 PLL_AVDD

- The PLL_AVDD filter (especially the capacitor) is placed close to the PLL_AVDD pin (Section 11).

H Associated Design Documentation

Document Title	Information	Document
Estimating Power Consumption For XS1-LF Devices	Power consumption	Link
XMOS Programming Guide	Timers, ports, clocks, cores and channels	Link
xTIMEcomposer User Guide	Compilers, assembler and linker/mapper Timing analyzer, xScope, debugger Flash and OTP programming utilities	Link

I Related Documentation

Document Title	Information	Document
xCORE200: the XMOS XS2 Architecture	ISA manual	Link
I/O timings for xCORE200	Port timings	Link
xCONNECT Architecture	Link, switch and system information	Link
XS1-LF Link Performance and Design Guidelines	Link timings	Link
xCORE-200 Clock Frequency Control	Advanced clock control	Link Link
XS1-L Active Power Conservation	Low-power mode during idle	Link

J Revision History

Date	Description
2015-03-20	Preliminary release
2015-04-14	Added RST to pins to be pulled hard, and removed reference to TCK from Errata Removed TRST_N references in packages that have no TRST_N New diagram for boot from embedded flash showing ports Pull up requirements for shared clock and external resistor for QSPI
2015-05-06	Removed references to DEBUG_N
2015-07-09	Updated electrical characteristics - Section 12
2015-08-27	Updated part marking and product code - Section 14
2015-11-23	Updated status of X2D04, X2D05, X2D06, X2D07 during boot - Section 8 Updated Schematics Design Checklist: GPIO for X2D04, X2D05, X2D06, X2D07 during boot - Section F
2015-12-18	Clarified connectivity of internal and external xCONNECT links - Sections 3 and 4 Made pin names canonical - Sections 3 and 4 Updated JTAG diagram - Section 10 Removed references to 400MHz parts - Section 12
2016-01-05	Updated signal tables to use VDDIO - Section 4 Updated IDD value - Section 12 Updated land pattern description - Section 11.1
2016-04-20	Typical internal pull-up and pull down current diagrams added - Section 12
2017-09-19	Added Absolute Maximum Ratings - Section 12.1 Reference document links updated - Section H
2018-03-23	Incorrect IDC0DE return value updated - Section 10
2020-10-05	Released documentation for A revision that uses different flash - Section 8



Copyright © 2020, All Rights Reserved.

Xmos Ltd. is the owner or licensee of this design, code, or Information (collectively, the "Information") and is providing it to you "AS IS" with no warranty of any kind, express or implied and shall have no liability in relation to its use. Xmos Ltd. makes no representation that the Information, or any particular implementation thereof, is or will be free from any claims of infringement and again, shall have no liability in relation to any such claims.

XMOS, xCore, xcore.ai, and the XMOS logo are registered trademarks of XMOS Ltd in the United Kingdom and other countries and may not be used without written permission. Company and product names mentioned in this document are the trademarks or registered trademarks of their respective owners.

