

XMOS™

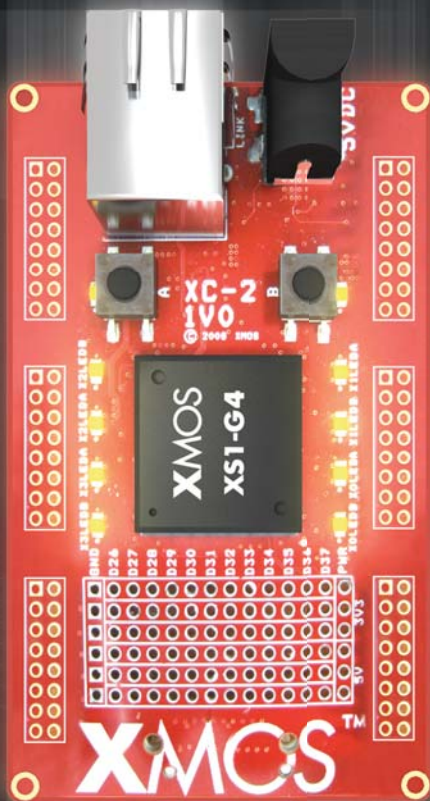

XC-2 Ethernet Kit

XC-2 Ethernet Kit

The XC-2 Ethernet Kit is a rapid and cost effective route for developing Ethernet-based products in XMOS Silicon. Based around the four-core XS1-G4 programmable device, the XC-2 Kit provides the hardware needed to connect to a 10/100 Ethernet system using an RJ45 socket.

The XC-2 Ethernet Kit includes:

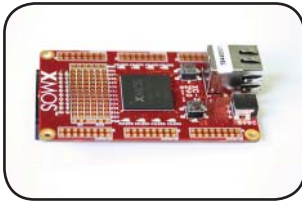

XC-2 Development Board



XTAG Connector



USB Cable



5V Power Supply

Getting Started

The XC-2 Kit includes a webserver application written in C and XC. The XS1-G4 serves the website, and drives the protocol stack and ethernet hardware.

To use the webserver you need to plug the XC-2 card into a local network or your PC. Make sure that you disable any firewall you may have running before trying to connect to the website. If you do not want to run the webserver please go to the *Debugging the XC-2 Card* section on page 5.

Connect the XC-2 to a network using DHCP



Plug-in the XC-2 using the 5V power supply. The PLL LED on the bottom of the board lights up to indicate that the board has been powered up.



Connect the XC-2 to your network using an ethernet cable (not supplied). An LED pattern flashes to show live connectivity.



The X1LEDA LED lights up to show that the application is running. The X2LEDB LED lights up to show the card is successfully connected to the network.

Open your browser and go to:

<http://xc2.local>.



Use the menu options to explore the device capabilities. You can flash the LEDs on the XC-2, read real-time information about board features, and change the board to use a static or automatic IP configuration.

Connect the XC-2 directly to a PC

Make sure that the XC-2 power supply is disconnected.

Configure your PC to connect to a valid static IP address on the 192.168.0 subnet, for example 192.168.0.101.

Connect the XC-2 to your PC using an Ethernet cable.

Hold down firmly Button A on the XC-2 and plug-in the 5V power supply to the XC-2 card. Keep Button A held down until the LEDs stop flashing to force the card into static IP mode.

Open your browser and go to <http://192.168.0.100>, the default static IP address of the XC-2 card.

Webserver application - XC-2 buttons

The type of IP address used to connect to the webserver is set in the Configuration page of the *xc2.local* website. Use the XC-2 buttons to override this setting when you start the device:

- Button A - uses a static IP address (default 192.168.0.100)
- Button B - uses an automatic IP address

Troubleshooting the webserver application

LEDs do not light up

- Check that the power supply is connected correctly

X2LEDB LED does not light up

- Check the ethernet cable is connected correctly to the XC-2
- If there is no DHCP server on network, it may take up to a minute to obtain an IP address

X2LEDB LED lights up but browser cannot load <http://xc2.local>

- Disable any firewall you may have running
- Configure your PC and XC-2 to use a static IP address. See the previous section *Connect the XC-2 directly to a PC*.

Debugging the XC-2 Card

The XC-2 Kit includes an XTAG connector and USB cable that can be used for loading and debugging programs on the hardware via JTAG. You can connect the XTAG device to an XC-2 at anytime.

Connect the XC-2 using a JTAG interface

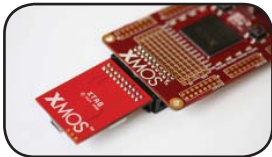

Connect the XC-2 to the XTAG using the IDC connector.



Connect the XTAG to your development system using the USB cable.

Log into a shell with root permissions, open the file `/etc/fstab` and add the line:

```
none /proc/bus/usb usbfs defaults,devmode=0666 0 0
```

Unmount the USB file system, for example:

```
umount /proc/bus/usb
```

Remount the USB file system, for example:

```
mount /proc/bus/usb
```

Log out from root access

When you have installed the drivers, you need to install the development tools which include a part of the GNU debugger and utilities for loading programs onto the card.

Install the software development tools

1. Download the software development tools from:
www.xmos.com/downloads

2. Install to tools to the directory /home/user. Type:

```
tar -xzf DesktopTools version.tgz -C /home/user
```

The archive is unpacked into the subdirectory XMOS/
DesktopTools/version/. This

3. Go to this directory and type:

```
source SetEnv
```

4. Type the following command:

```
xrun --listdevices
```

All the XMOS devices attached to your system are listed.

Next Steps

Information on using the XC-2 and development tools is available from www.xmos.com/support including:

XC-2 Ethernet Kit Tutorial - how to write programs in XC for the XC-2 card

Desktop Tools User Guide - how to use the development tools

XC-2 Hardware Manual - hardware features on the XC-2 board

Further information on configuring the USB drivers and additional documentation is available from:

www.xmos.com/support

Firmware Updates

You can check the webserver firmware version using the Board Information page on the *xc2.local* website. Check www.xmos.com/xc2 for any firmware updates and instructions on how to update the device.

XC-2 Card Features

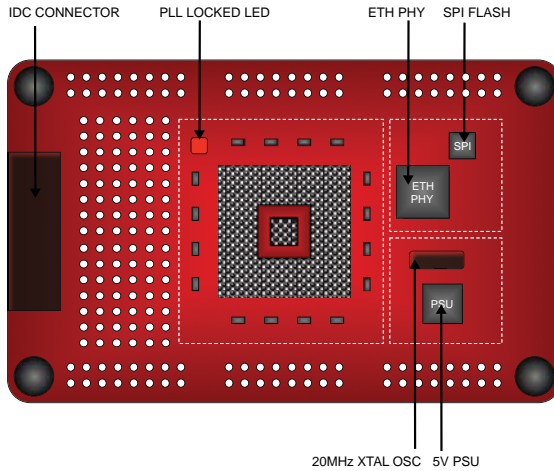
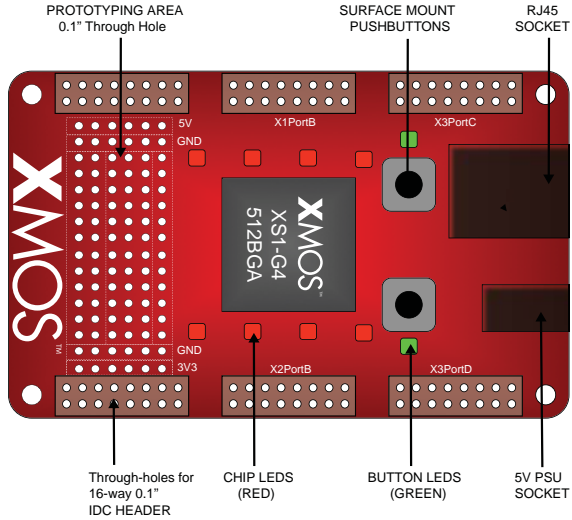

Hardware Notice & Disclaimer

The following terms and conditions apply to the XMOS goods in your possession:

Definition

'XMOS' means XMOS Limited

'Customer' means the person (legal or natural) to whom the Goods are supplied.

'Goods' means all hardware, software or services which are to be supplied to the Customer by XMOS under this Notice & Disclaimer.

Warranty & Liability

1.1 Hardware will be free from defects in materials and workmanship for a period of 12 months from date of purchase. This warranty shall not apply to any defect, failure or damage caused by improper use or improper or inadequate maintenance or care of the hardware.

1.2 XMOS's obligations and liabilities in respect of the Goods shall be limited to those set out expressly herein and XMOS specifically excludes without limitation the implied conditions of satisfactory quality and fitness for any particular use or purpose. XMOS shall have no liability whatsoever in respect of any advice and/or information which may be given to the Customer by XMOS relating to Goods, their configuration or otherwise.

1.3 The Customer shall ensure that any warranty and maintenance service performed on Goods is performed by a qualified representative authorised by XMOS to offer warranty and maintenance on those Goods.

1.4 XMOS makes no representation and gives no warranty in respect of the sources of origin of manufacture or production of the Goods or any part thereof.

1.5 Without prejudice to Clause 1.1 and 1.2 in the event of XMOS being shown to have been negligent in the supply of Goods or the provision of services its liability:

1.5.1 for death or personal injury of any person caused by such negligence shall be unlimited.

1.5.2 in respect of any defects in or failure of hardware or for the loss or damage attributable thereto or to the negligence of its employees in connection with the performance of their duties hereunder, shall be limited to the making good by replacement or repair of such hardware which upon inspection by XMOS appear to be defective and in any event XMOS's maximum aggregate liability arising in respect of the supply of Goods or services shall be limited to the original VAT exclusive price for such Goods or services.

1.6 XMOS shall not in any circumstances whatsoever be liable for indirect or consequential loss including but not limited to loss of profits, revenue, business, contracts loss of data or use and shall have no liability for any claim based upon the combination operation or use of any Goods with equipment data or programming not supplied by XMOS or based upon a modification of the Goods.

1.7 Any action against XMOS must be brought no later than 12 months after the Customer becomes aware that a cause of action has arisen.

Export and Restrictions on use

1.8 The Customer acknowledges that the Goods may be subject to US and local government export controls. Where these apply it is the Customer's sole responsibility to obtain authorisation from the appropriate authorities before reexporting the Goods from the country of purchase.

1.9 All Goods are manufactured for standard commercial uses and are not intended to be sold or licensed for use in critical safety/health systems or in nuclear facilities, other nuclear applications, mass transportation and aviation applications.

Intellectual Property & General

1.10 The Customer recognises XMOS's and its licensors' ownership of and title to all trademarks, service marks, trade names, patents, copyright and other intellectual property rights comprised in the Goods and any accompanying materials.

1.11 The Customer will take no action to violate, obliterate, remove, alter, conceal or misuse any such marks, trade name or copyright notice.

1.12 The Customer will promptly notify XMOS if it becomes aware of any infringement of such intellectual property rights by any third party and shall provide its reasonable assistance to XMOS and/or the manufacturer in connection with any resultant proceedings.

1.13 These Conditions shall be construed according to the laws of England. The Customer and XMOS submit to the non-exclusive jurisdiction of the English Courts in connection with any dispute or proceedings arising out of any contract incorporating these Conditions.

© 2009 XMOS Limited. All Rights Reserved