

Audio Class 2.0 allows USB 2.0 High Speed implementations of USB audio, with 24-bit audio and sample frequencies up to 192kHz for superior audio quality.

XMOS has developed the USB Audio 2.0 Reference Design Kit for designers targeting the USB audio market. The software framework provides USB High Speed and Audio Class 2.0, with options to add your own audio processing, interfaces and peripherals.



Using XMOS event-driven processor technology, the USB Audio 2.0 Reference Design Kit offers a complete software programmable solution for Audio Class 2.0. The compact credit card sized board is an ideal reference design for your production audio product.

### ***XMOS Event-Driven Processors***

The XS1-L1 device at the heart of this system gives high levels of processing and flexibility from the 400 MIPS available. The XS1-L1 can be programmed in C, XC and C++ to handle:

- Digital audio interfaces including I<sup>2</sup>S and S/PDIF
- Audio DSP algorithms
- Custom peripherals (front of box controls) and control code



### ***Example Applications***

Features	Benefit
XMOS event-driven processor IC (XS1-L1)	Integrate Audio DSP, interfaces and control code
USB 2.0 High Speed	Supports 24-bit, 192kHz audio for high quality audio with multichannel capability
Audio Class 2.0 compliant	Plug and Play
Asynchronous mode	Low latency, bit perfect digital audio with high quality local media clock
Stereo CODEC for analogue input/output and S/PDIF TOSLINK stereo output	Choice of digital or analogue sources
Software defined workflow, complete source code available	Accelerated product development
SPI Flash with optional secure boot	Store and upgrade application code with IP protection

## USB Audio 2.0 Reference Design Application Brief

The USB Audio 2.0 Reference Design is suitable for use in a wide range of applications, including:

- USB sound cards
- Home theatre/entertainment applications
- Musical Instruments

### Application Programming

Applications for the XS1-L1 device are developed using an embedded software design flow and any combination of C, C++ and XC. XC includes intuitive extensions for concurrency, communications and timed I/O operations. The thread diagram below shows the internal software structure for the USB Audio 2.0 Reference Design software framework. The software source code is available from XMOS allowing customers to modify, enhance and optimise the design to their exact requirements.

### Generic Software Thread Diagram for USB Audio 2.0

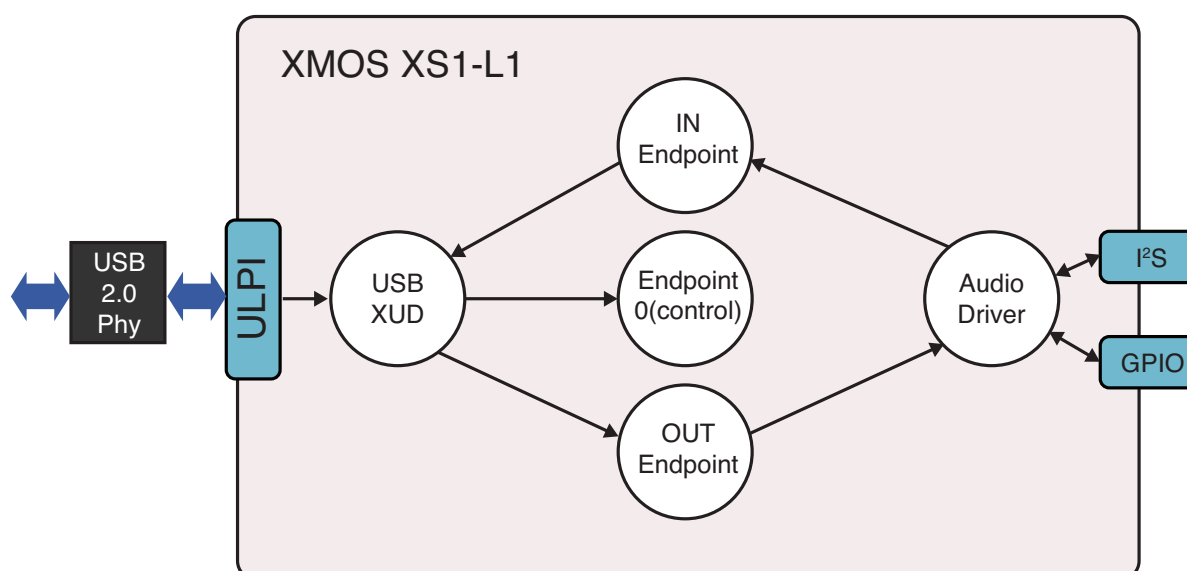

To begin your evaluation of the USB Audio 2.0 Reference Design, XS1-L1 Edition, please contact your local sales representative: <http://www.xmos.com/products/distributors>.

For more information about XS1-L devices and our free Design Tools, please visit [www.xmos.com](http://www.xmos.com).

**Note:** The USB Audio 2.0 Reference Design board requires a USB Audio 2.0 class compliant driver available on the host. This functionality is built into Mac OS 10.6 or later. For Windows driver availability, please contact your local sales representative: <http://www.xmos.com/products/distributors>.