

DISCOVER SOFTWARE DESIGNED SILICON

The XC-1 Development Kit is a quick and cost effective route to trying out your design ideas using XMOS chips. The kit includes the XC-1 Development Card, USB programming/power cable, and access to the online development tools, tutorials and documentation.

The credit card sized XC-1 board is based on the four-core XS1-G4 programmable device, and provides basic I/O including LEDs, switches and a speaker for use with a software-driven 1-bit DAC. The XC-1 is easily interfaced to your system hardware via 60 user I/O pins, and you can integrate additional components using the 0.1" pitch through-hole prototyping area.

RAPID DEVELOPMENT OF YOUR SYSTEM

Thanks to an embedded software design flow, development cycles with XMOS devices are extremely short. The XC-1 is supported by a complete suite of design tools, and to accelerate your learning we provide a comprehensive set of tutorials, demonstration projects and quick start guide.

The small size of the XC-1 Development Card makes it ideal for integration into target applications and embedded systems. The board is powered directly from the host workstation's USB port which also serves as the debug connection. The XC-1 Development Kit provides everything required to start developing your application.

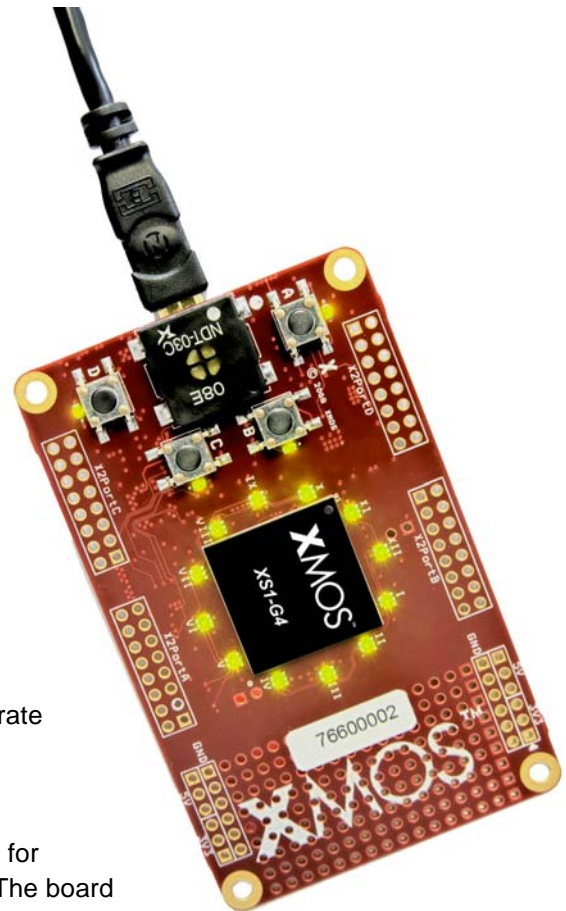

XC-1 HARDWARE DEVELOPMENT BOARD AT A GLANCE

- XS1-G4 four-XCore™ 400MHz device: 1600 MIPS, 256KB RAM, 32KB OTP
- Development board features:
 - USB power and host debugger connection
 - Four pushbutton and LED pairs
 - 12 bi-colour LEDs
 - Integrated speaker (can be driven via software DAC)
 - 60 pins user I/O expansion from two XCores™
 - Two external port expansion connections
 - Credit card sized (85 x 54 mm)
- Complete development tool suite
 - C and XC compilers, linker and mapper
 - Simulator, visualisation tools and in-circuit visual debugger
- Tutorial suite with examples
 - Clock / Countdown timer, audio synthesiser, reaction game and more
- Complete kit allows you to design applications in minutes

XC-1 DEVELOPMENT CARD BLOCK DIAGRAM

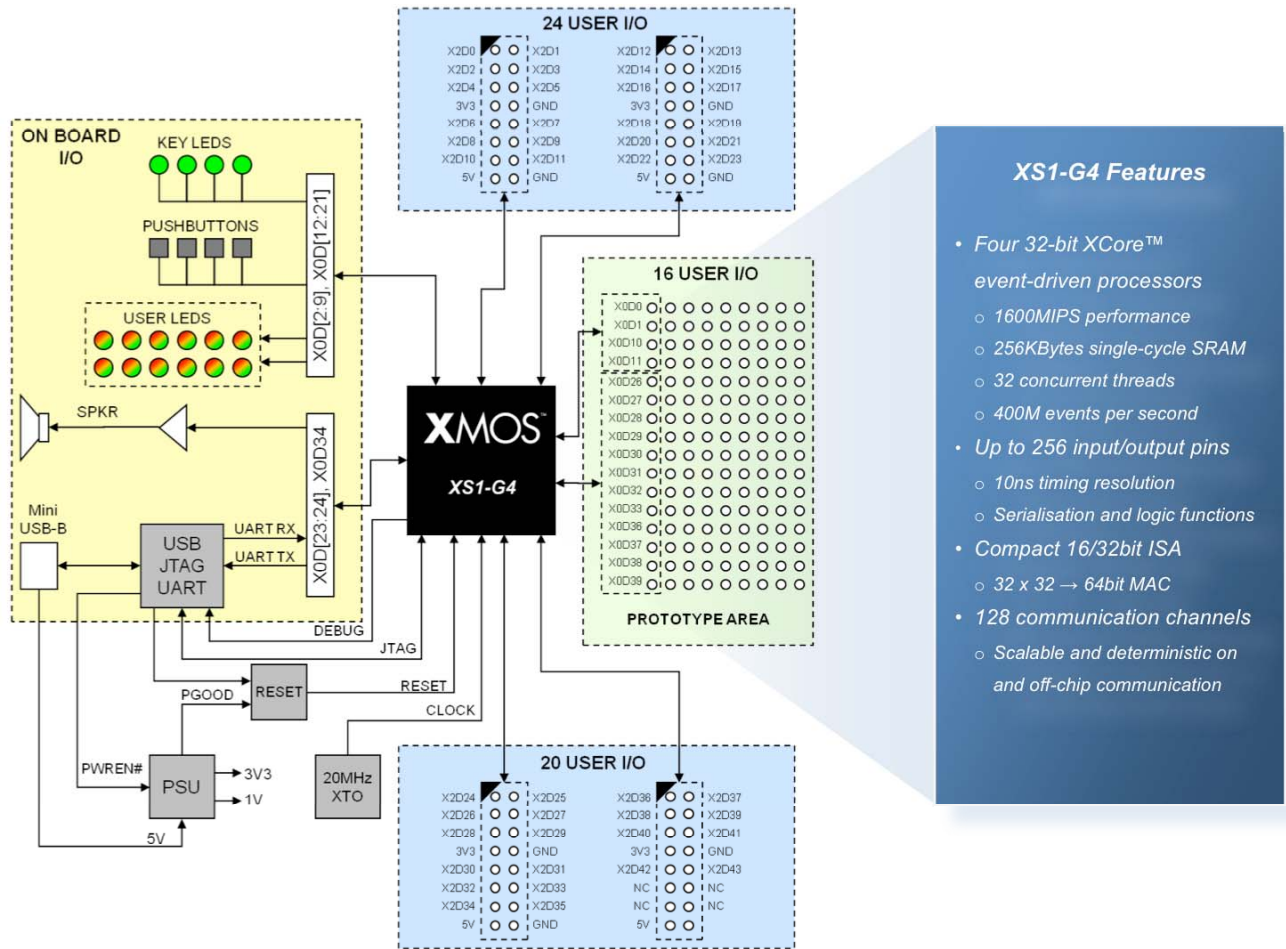

XS1-G4 Features

- Four 32-bit XCore™ event-driven processors
 - 1600MIPS performance
 - 256KBytes single-cycle SRAM
 - 32 concurrent threads
 - 400M events per second
- Up to 256 input/output pins
 - 10ns timing resolution
 - Serialisation and logic functions
- Compact 16/32bit ISA
 - 32 x 32 → 64bit MAC
- 128 communication channels
 - Scalable and deterministic on and off-chip communication

DESIGN TOOLS

The XC-1 Development Card is supported by an integrated development environment, a complete tool suite that integrates C and XC compilers, a simulator, visualisation tools and a debugger.

Applications are written in C, C++ and the XMOS-originated XC, an extension to C that supports concurrent and real-time programming using channel-based communications and event driven control. A step-by-step tutorial is provided that will have you proficient in XC within an hour.

For more information about XMOS or our products, to purchase an XC-1 Development Kit, or to explore our web-based development tools, please visit www.xmos.com/xc1 or contact your local XMOS sales representative.

